

SCAFFOLDING INTERMEDIATE

CPCCLSF3001

Licence to erect, alter and dismantle scaffolding
intermediate level

LEARNER WORKBOOK STUDENT COPY



**EASY
GUIDES**
Australia Pty Ltd

www.easyguides.com.au

National Licence
RTO-VET Learning Materials

Contents

Language – Literacy – Numeracy (LLN)	4
How to get the most out of this book	5
Things to consider when learning	6
Learning support materials	7
Learning and practical tasks	8
What is a intermediate scaffolding?	9
Introduction to high risk licensing	11
National Vocational Education and Training (VET) licensing pathway	12
Training and assessment requirements	13
Record of training logbook	14
Who has a duty of care?	15
Where to find licensing information	17
Introductory training exercise	18
Element 1—Plan task	21
Element 2—Select and inspect plant and equipment	41
Element 3—Set up task	53
Element 4—Undertake Intermediate Scaffolding Activities	63
Element 5—Complete Task	77
Performance Training Tasks	83
Beaufort Wind Scale – Flash/bang rule	104
Thank you	105
Continuous improvement form	106

What is intermediate scaffolding?

Intermediate scaffolding is work with:

- Prefabricated scaffolds
- Tube-and-coupler scaffolds including tube-and-coupler covered ways and gantries
- Cantilevered hoists with a working load limit not exceeding 500 kg (materials only)
- Ropes
- Gin wheels
- Safety nets and static lines
- Bracket scaffolds (tank and formwork)
- Cantilevered crane loading platforms
- Cantilevered and spurred scaffolds
- Barrow ramps and sloping platforms
- Scaffolding associated with perimeter safety screens and shutters
- Mast climbers.



Element 1

Plan Task



This element covers performance criteria:

- 1.1 Review task instructions, consult with relevant persons to seek clarification as required, and obtain relevant workplace information.
- 1.2 Obtain and interpret information, including safe work method statements (SWMSs), required to ensure that activities are performed in compliance with workplace-specific and safe work requirements.
- 1.3 Obtain and interpret information required to ensure that equipment inspection, use, maintenance and storage complies with manufacturer requirements.
- 1.4 Identify workplace and task-specific hazards and determine required risk controls and safety measures and equipment, including signs and barricades, personal protective equipment (PPE), and fall prevention and fall arrest equipment
- 1.5 Identify methods of moving and placing tools, equipment and materials to minimise the risk of falling objects, to avoid inappropriate carrying on ladders and to minimise hazardous manual tasks.
- 1.6 Identify required scaffold and associated equipment.
- 1.7 Calculate loads exerted on and by the scaffold and scaffolding equipment.
- 1.8 Establish required communication methods with relevant persons.

Performance Criteria: 1.1

Task to be undertaken is assessed

Before you set up a scaffold, ask about any site rules, procedures (things you should do) and policies that may affect your task.



Theory Training Task 1

Performance Criteria: 1.1, 1.2, 1.4

- a) Name three people you may need to check with about the hazards and working on a site.

.....

.....

.....

.....

.....

.....



- b) What local site conditions would you check when you assess your task?

.....

.....

.....

- c) You need to know the laws that cover your workplace.
Explain each of the following:

WHS/OHS ACTS

.....

Regulations

.....

Codes of Practice/Compliance Codes

.....

Australian Standards

.....



Theory Training Task 2

Performance Criteria: 1.1, 1.2, 1.4

a) What is a Job Safety and Environment Analysis (JSEA) used for?

.....
.....
.....
.....
.....
.....

Job Safety and Environment Analysis (JSEA) Worksheet			
Company name:	Date:	JSEA No:	
Site name:	Permit to work requirement:	<input type="checkbox"/> Yes <input type="checkbox"/> No	
Contractor:	Approved by:		
Activity:			
Activity List the tasks needed to do the job in the order they are done.	Hazards Identify each task list the hazards that could cause injury when the task is done.	Risk control measures List the control measures needed to remove or minimise the risk of injury from the hazard once they have identified.	Who is responsible? Write the names of the person responsible (supervisor or abettor) for putting the control measures in place.

b) What is the name of a similar form that might be used instead of a JSEA?

.....
.....



Theory Training Task 3

Performance Criteria: 1.1

A high risk work licence for Intermediate Scaffolding allows you to do some types of scaffolding.

Are the following statements **True** or **False**?

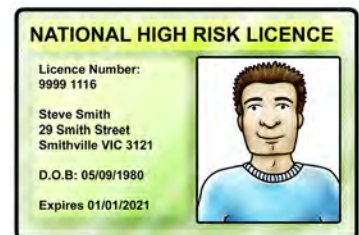

A person with an intermediate scaffolding licence can build tube and coupler scaffolds.

True **False**

A person with an intermediate scaffolding licence can erect a cantilevered hoist with a working load limit not exceeding 500 kg (materials only).

True **False**

A person with an intermediate scaffolding licence can erect cantilevered scaffolds.

True **False**

A person with an intermediate scaffolding licence can build suspended scaffolds.

True **False**

A person with an intermediate scaffolding licence can build hung scaffolds.

True **False**

Performance Criteria: 1.6

Identify scaffold and associated equipment

Intermediate scaffolding includes a wide range of scaffold types and associated equipment that you must be aware of. It is important you know the correct terminology and the names of components.

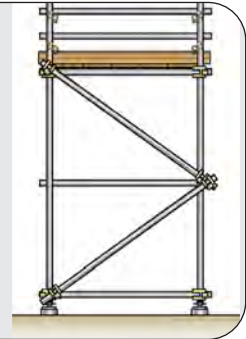

Theory Training Task 14

Performance Criteria: 1.6

Below is a diagram of a scaffold. The diagram has arrows pointing to parts of the scaffold.

In the space provided, name the scaffold parts.

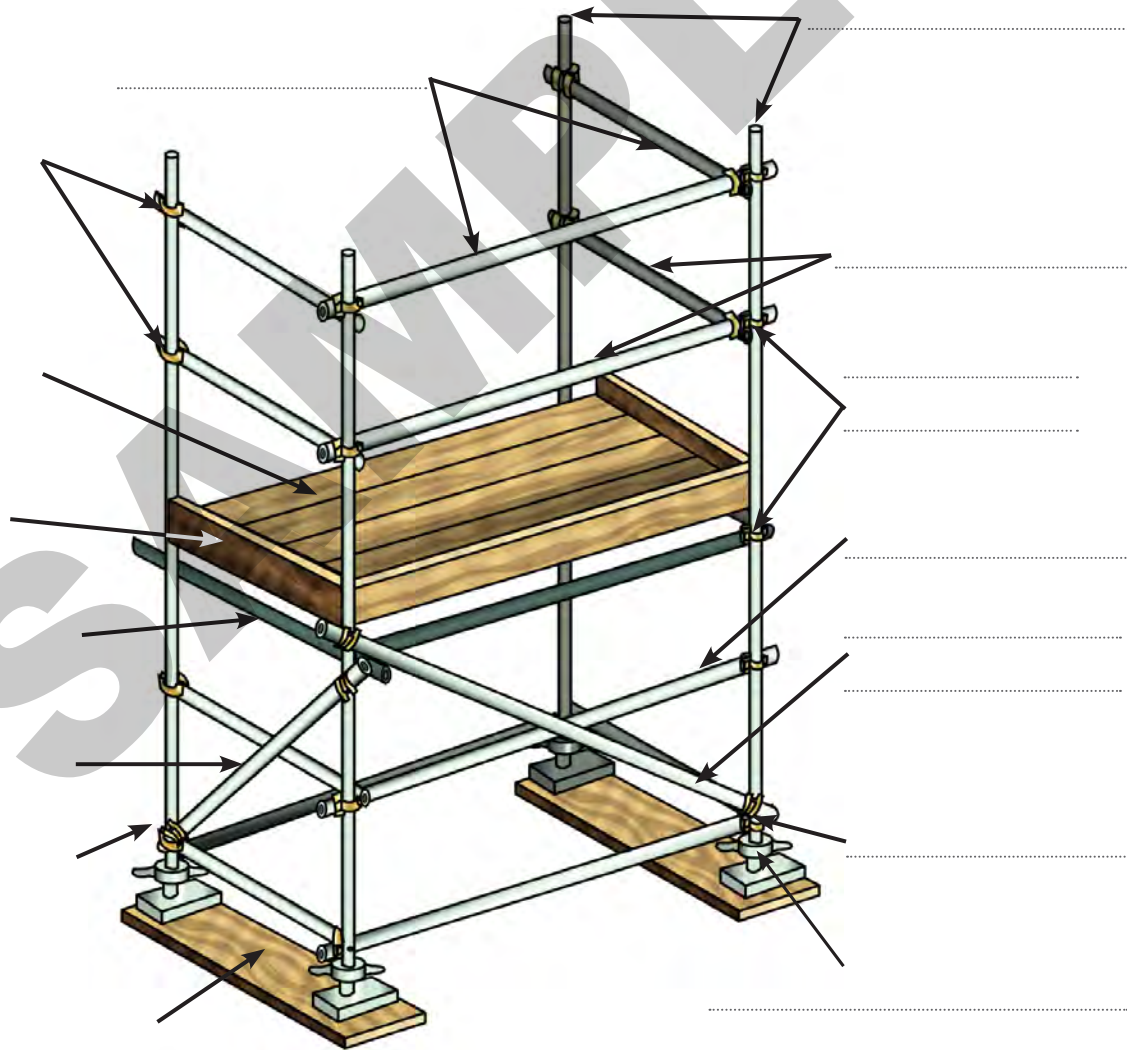



Theory Training Task 15

Performance Criteria: 1.6

What types of scaffold are you allowed to erect with an intermediate scaffolding licence?

.....

.....

.....

.....

.....

.....

.....

.....

.....

.....



Theory Training Task 16

Performance Criteria: 1.6

Below are diagrams of different types of scaffolds.

Draw lines to match the correct names with the scaffolds.

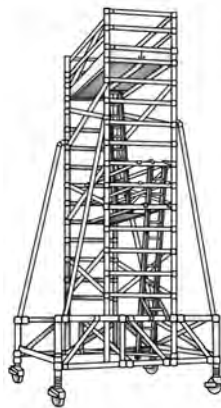
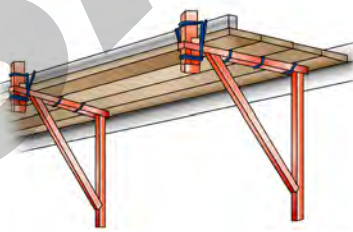
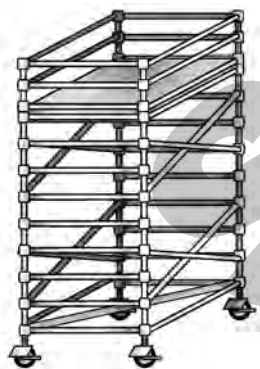

Mobile scaffold

Modular birdcage scaffold

Bracket scaffold

Tower frame scaffold

Element 2

Select and inspect equipment



This element covers performance criteria:

- 2.1. Select risk-control equipment, including fall prevention and fall arrest equipment, and check that it is working and fit for purpose.
- 2.2. Safety and check PPE.
- 2.3. Inspect scaffold and associated equipment for defects, and isolate, tag out, report and record defective items.
- 2.4. Select communication equipment and check that it is working and fit for use.

Performance Criteria: 2.1

Select and inspect scaffolding equipment

Select risk-control equipment, including fall prevention and fall arrest equipment, and check that it is working and fit for purpose



Theory Training Task 25

Performance Criteria: 2.1

It is essential that the equipment you use meets all regulatory requirements and is the most appropriate for the job you are to do.

- a) What is the minimum width and thickness of a base plate?

.....

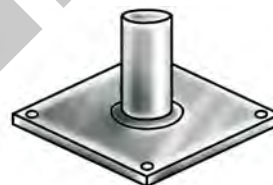

- b) How far should the spindle of an adjustable base plate extend above the maximum nut extension?

.....

- c) What is the maximum extension on an adjustable plate?

.....

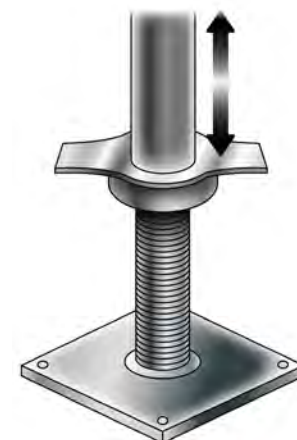

- d) What is the maximum load allowed on an adjustable base plate?

.....

- e) What is the minimum width of timber used as a sole plate?

.....

- f) What is the usual width of a scaffold plank?

.....



- g) What is the minimum thickness of a solid timber scaffold plank?

.....

Element 3

Set up task



This element covers performance criteria:

- 3.1. Establish and maintain communication with relevant persons to ensure task plan and risk controls are communicated clearly, including any impact on other workplace activities.
- 3.2. Ensure risk controls and safety measures and equipment have been put in place, including the fitting, adjusting and anchoring of fall protection equipment.
- 3.3. Consult with relevant persons to ensure that ground and foundation have been assessed as suitable for task.
- 3.4. Prepare footings to support scaffold and scaffold equipment.
- 3.5. Prepare scaffold and scaffold equipment, and place in a stable position ready for erection.

Performance Criteria: 3.3

Check ground conditions

Before you set up the scaffold, check the ground will support a scaffold.



Theory Training Task 38

Performance Criteria: 3.3

Are the following ground conditions safe for you to set up scaffolding or do you think they need more checking to make sure they are stable? (Circle your answer.)

Soft clay	Safe	Needs more checking
Stiff clay	Safe	Needs more checking
Dry sand	Safe	Needs more checking
Granite	Safe	Needs more checking
Shale	Safe	Needs more checking
Gravel (road base)	Safe	Needs more checking



Theory Training Task 39

Performance Criteria: 3.3

You may set up a scaffold on a suspended floor or temporary formwork. What sorts of questions would you ask yourself?

.....

.....

.....

.....

.....

.....

.....

.....

.....

.....

.....

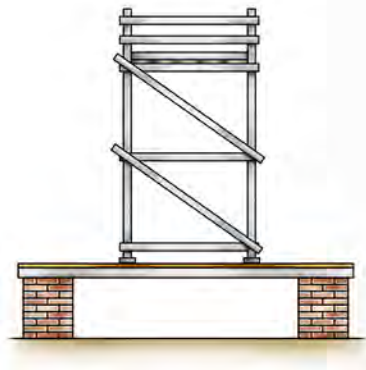

Performance Criteria: 3.4

Prepare footings

To keep the scaffold stable, you need to properly prepare the footings.

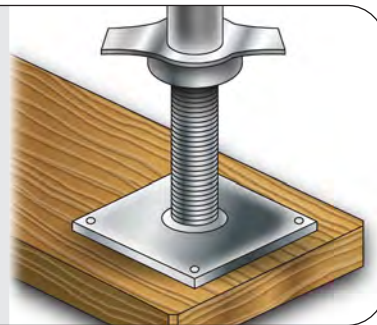

Theory Training Task 40

Performance Criteria: 3.4

Good foundations are essential. Often scaffolding needs more than baseplates to safely support and distribute the load. For surfaces like pavements or tarmac, soleboards are necessary.

- a) What is the minimum size and thickness of a soleboard?

.....

.....

- b) On uneven ground you must cut steps for the baseplates.
What is the minimum step size to keep the scaffold stable?

.....

.....



Theory Training Task 41

Performance Criteria: 3.4

When do you use soleplates and adjustable baseplates?

.....

.....

.....

.....

.....



Performance Criteria: 3.5

Prepare scaffolding equipment

Prefabricated scaffolding is a kit of parts that make up one full scaffold set. It comes with a set of instructions that tell you how to erect, dismantle, transport, store and maintain the scaffolding.



Theory Training Task 42

Performance Criteria: 3.5

- a) You have a hook-type gin wheel without a safety catch. How do you get it ready for use on a scaffold?



.....

.....

- b) Below are drawings of various hitches that you might need to use as a scaffolder. Write the name of each hitch in the space below the drawing.

