

LEARNER GUIDE



Elevating Work Platform

RII COMPETENCY

Training support material for:

RIIHAN301E

Operate elevating work platform
(Boom length less than 11 metres)

Produced by:



Introduction to Elevating work platforms



What is a boom type elevating work platform?

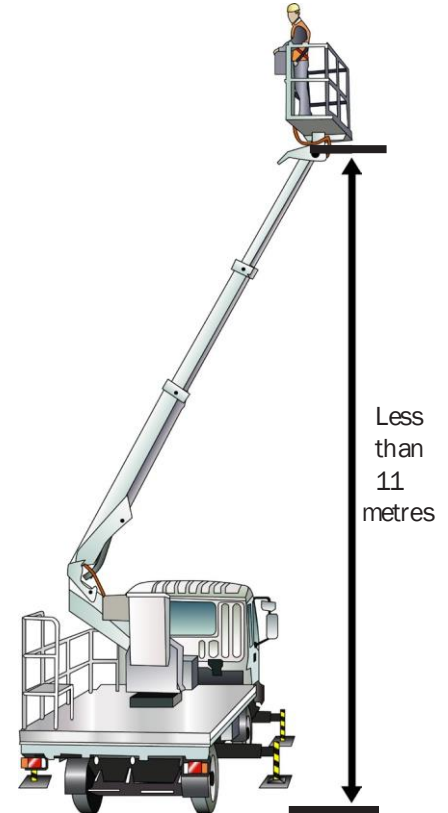
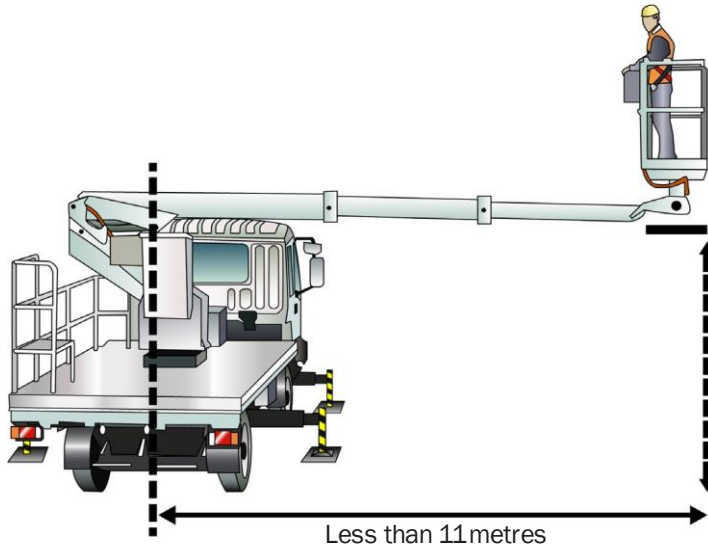

Parts of a boom type elevating work platform

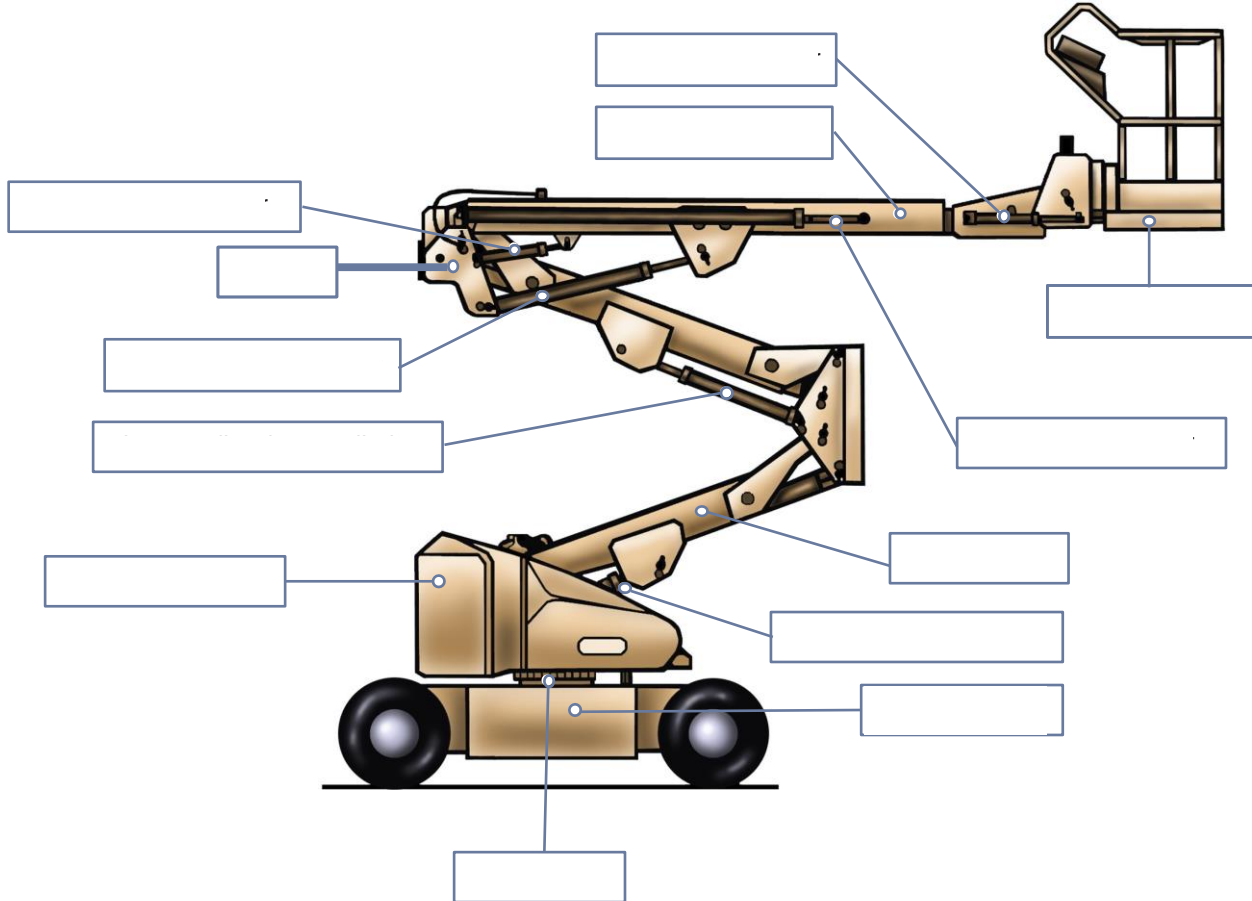

Types of elevating work platforms

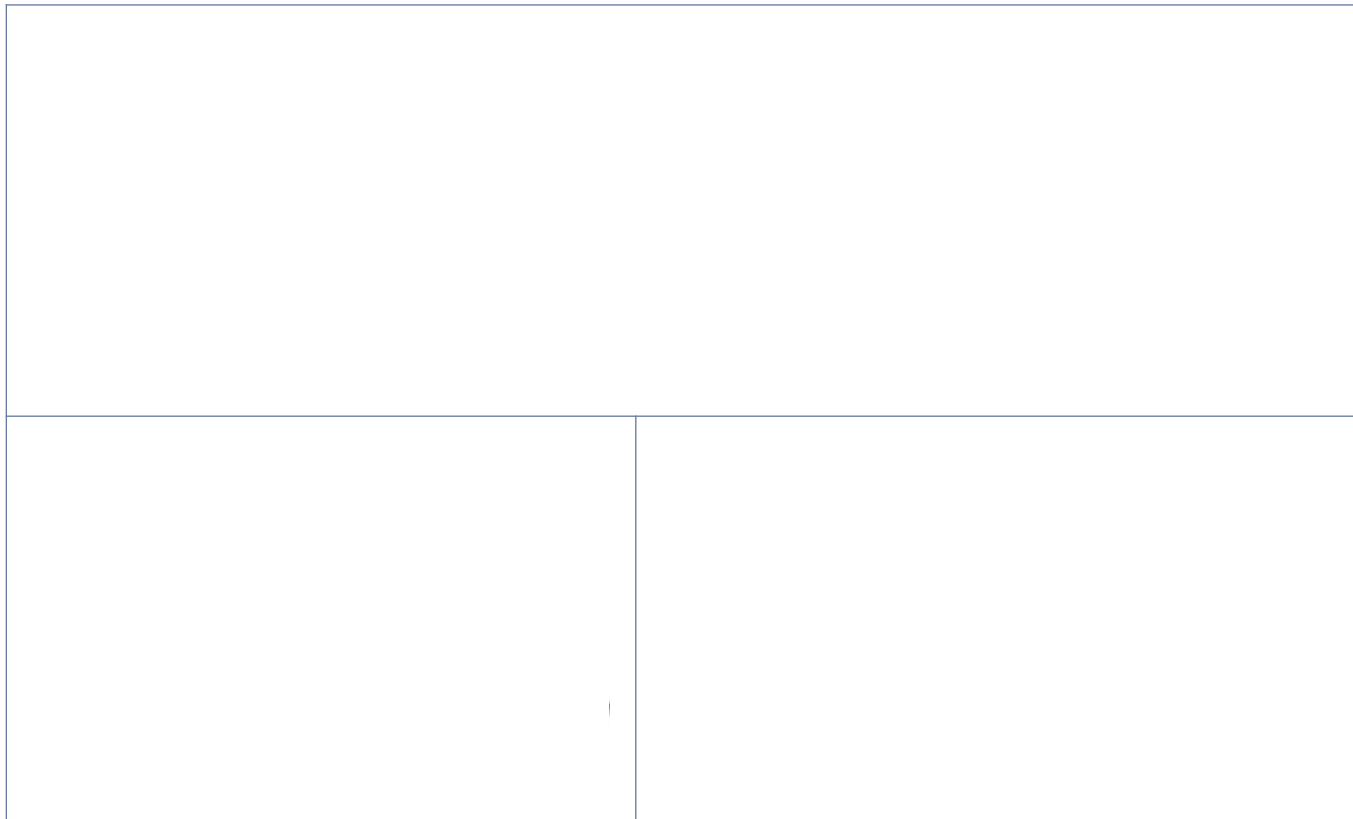

Types of EWP (continued)

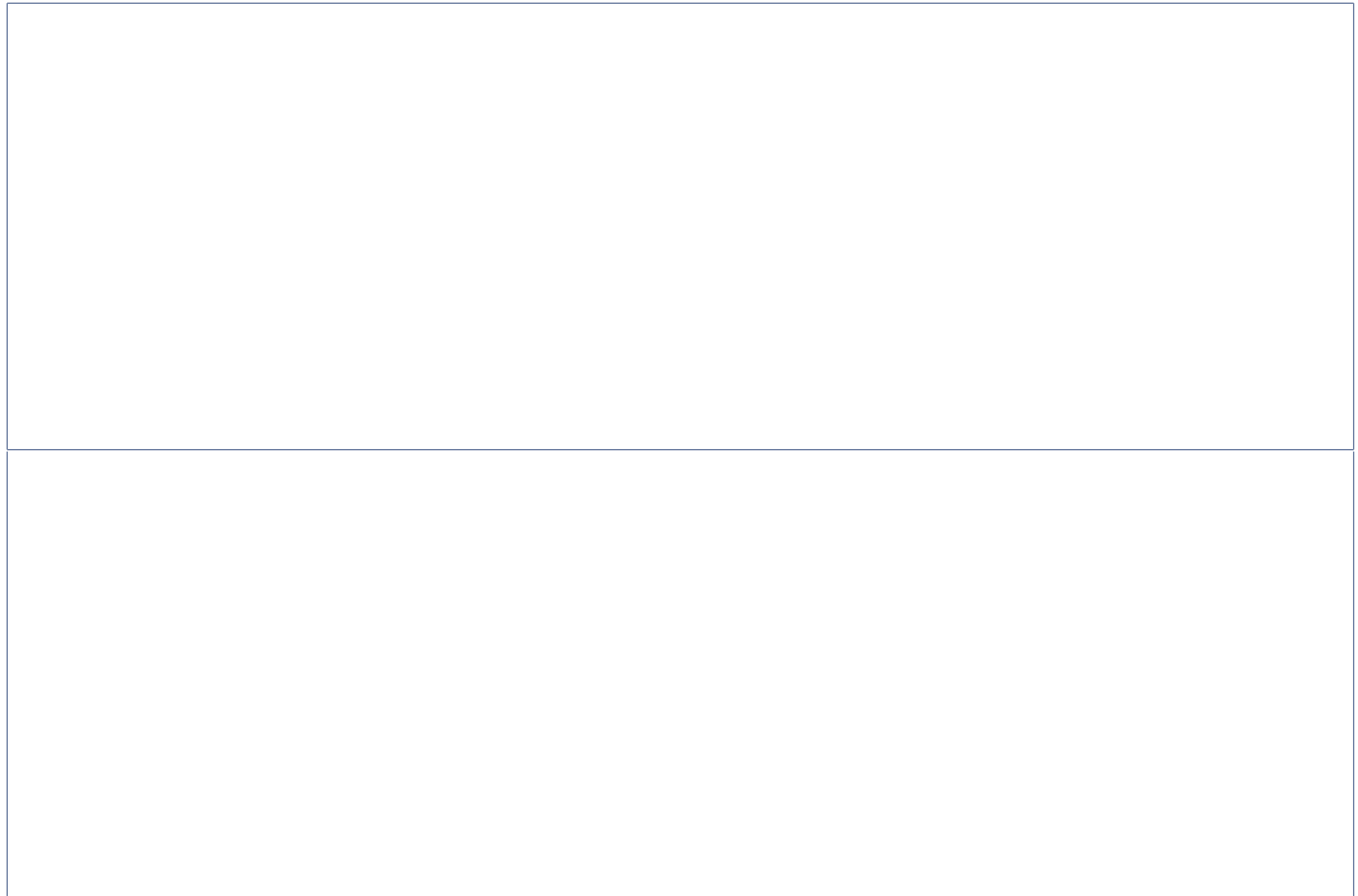

Plan and prepare for operating an elevating work platform

Element 1



Safety information and work requirements

Work requirements

Work requirements (continued)

--	--	--

Tools and equipment

Selecting the correct EWP



Loads and forces

Working load limit (WLL)

Working out the weight of the load

<hr data-bbox="124 1005 580 1013"/>		

QUESTION 5

When working with elevated work platforms, there are documents, called compliance documents.

What do these documents tell you?

QUESTION 7

How can you find information about safety and work procedures?

7

QUESTION 8

You need to know the Rated Platform Capacity and the Working Load Limit (WLL) of the EWP.

Where can you find this?

QUESTION 10

How can you find out the weight of everything in the basket?