

ORDER PICKING FORKLIFT TRUCK LEARNER WORKBOOK

TRAINER'S MARKING GUIDE WITH MODEL ANSWERS

TLILIC0004

Licence to operate an order picking forklift truck

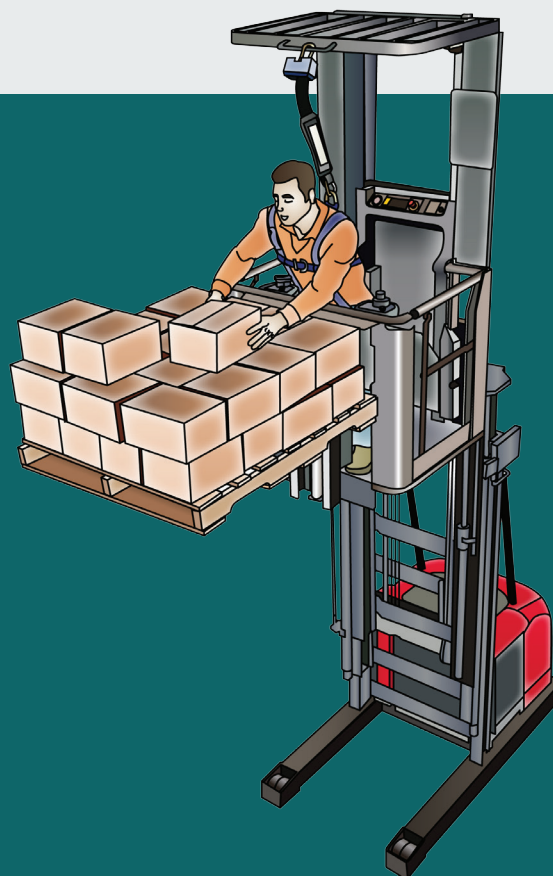

 **EASY
GUIDES**
Australia Pty Ltd
www.easyguides.com.au



Contents

Language – Literacy – Numeracy (LLN)	4
How to get the most out of this book	5
Things to consider when learning	6
Learning support materials	7
Learning and practical tasks	8
What is an order picking forklift truck?	9
Parts of an order picking forklift truck.....	10
Data plate	11
Introduction to high risk licensing	13
New National Vocational Education and Training (VET) licensing pathway	14
Training and assessment requirements	15
Record of training logbook	16
Who has a duty of care?	17
Where to find licensing information	19
Introductory training exercise	20
Part 1—Prepare for hazards	23
Practical Task 1	31
Practical Task 2	32
Part 2—Check the order picking forklift	35
Practical Task 3	44
Part 3—Plan the move	47
Practical Task 4	55
Part 4—Move the load	59
Practical Task 5	65
Part 5—Shut down and secure the order picking forklift	67
Practical Task 6	73
Thank you	75
Continuous improvement form	76

What is an order picking forklift truck?

An order picking forklift truck (also known as a stock picker) is different from other forklifts.

- On an order picking forklift the mast is fixed and cannot tilt forwards.
- An order picking forklift lifts and lowers the operator with the load.
- The controls travel with the operator.

Controls travel with operator

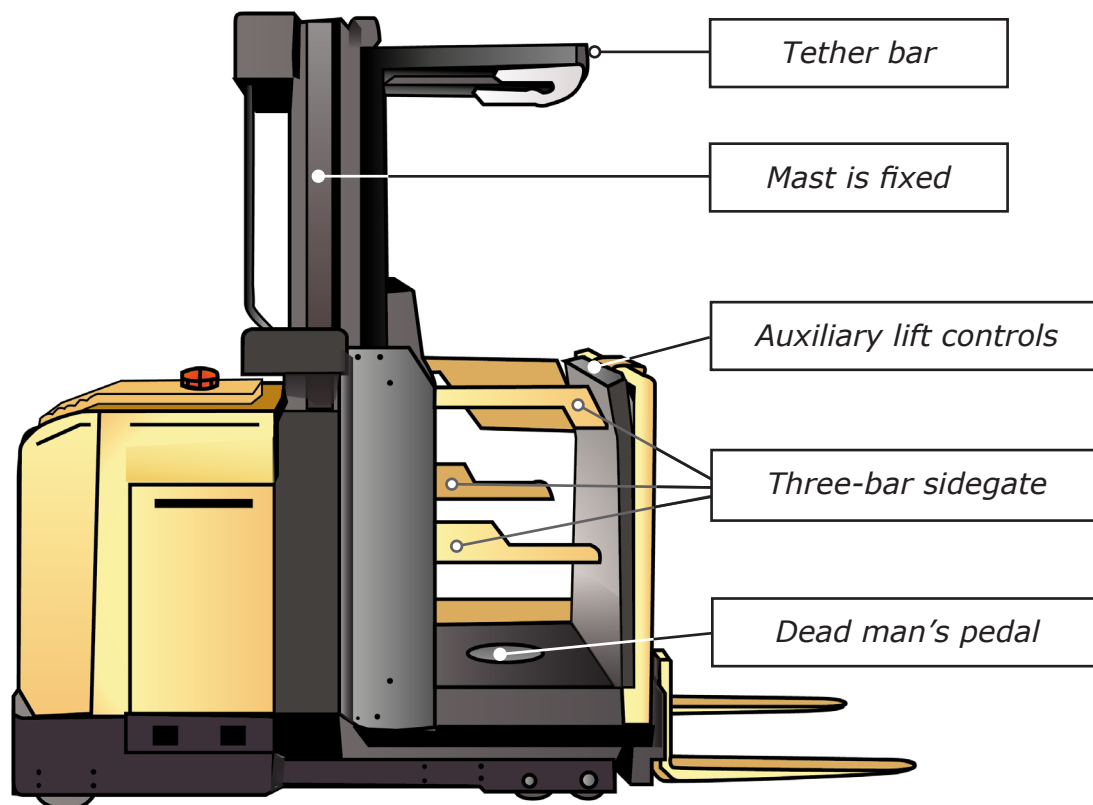

Operator is lifted and lowered with the load

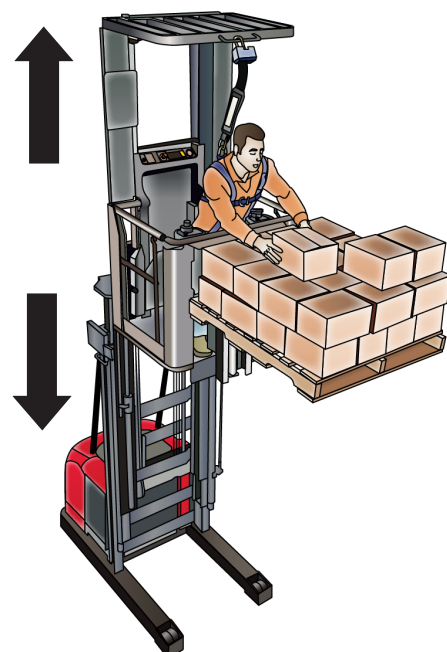

Parts of an order picking forklift truck

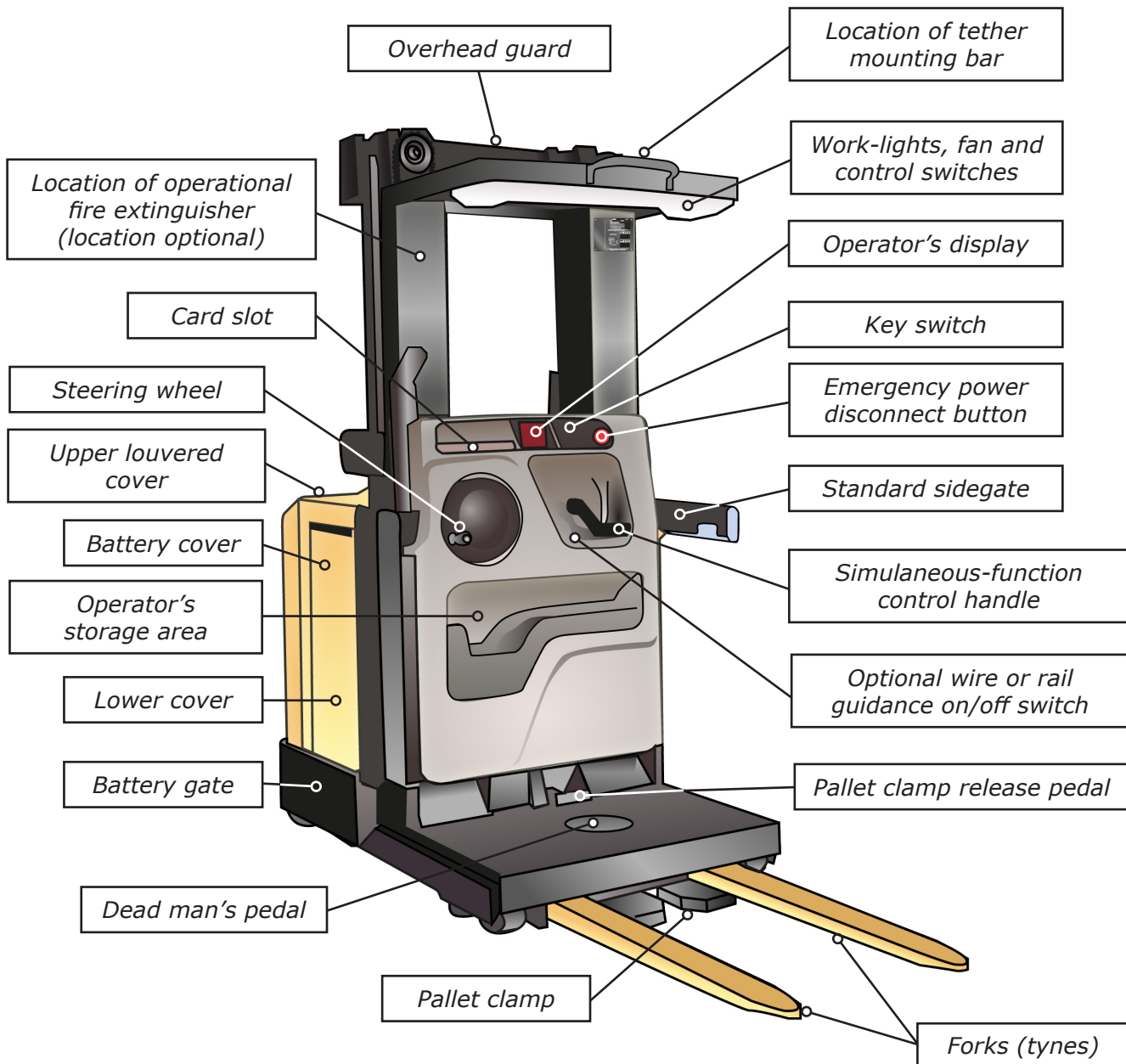

Note:
 This order picking forklift has lock-down bars.
 Some order picking forklifts have a cage.

Data plate

The order picking forklift and any attachments used with it will have a data plate.

- This data plate shows you how much weight the forklift or attachments can lift.
- Trying to lift more than the data plate allows will damage the forklift or the load. It can cause the forklift to become unstable and it may even tip over.
- If the data plate on the order picking forklift you are about to use is missing or unreadable, **do not** use the order picker.

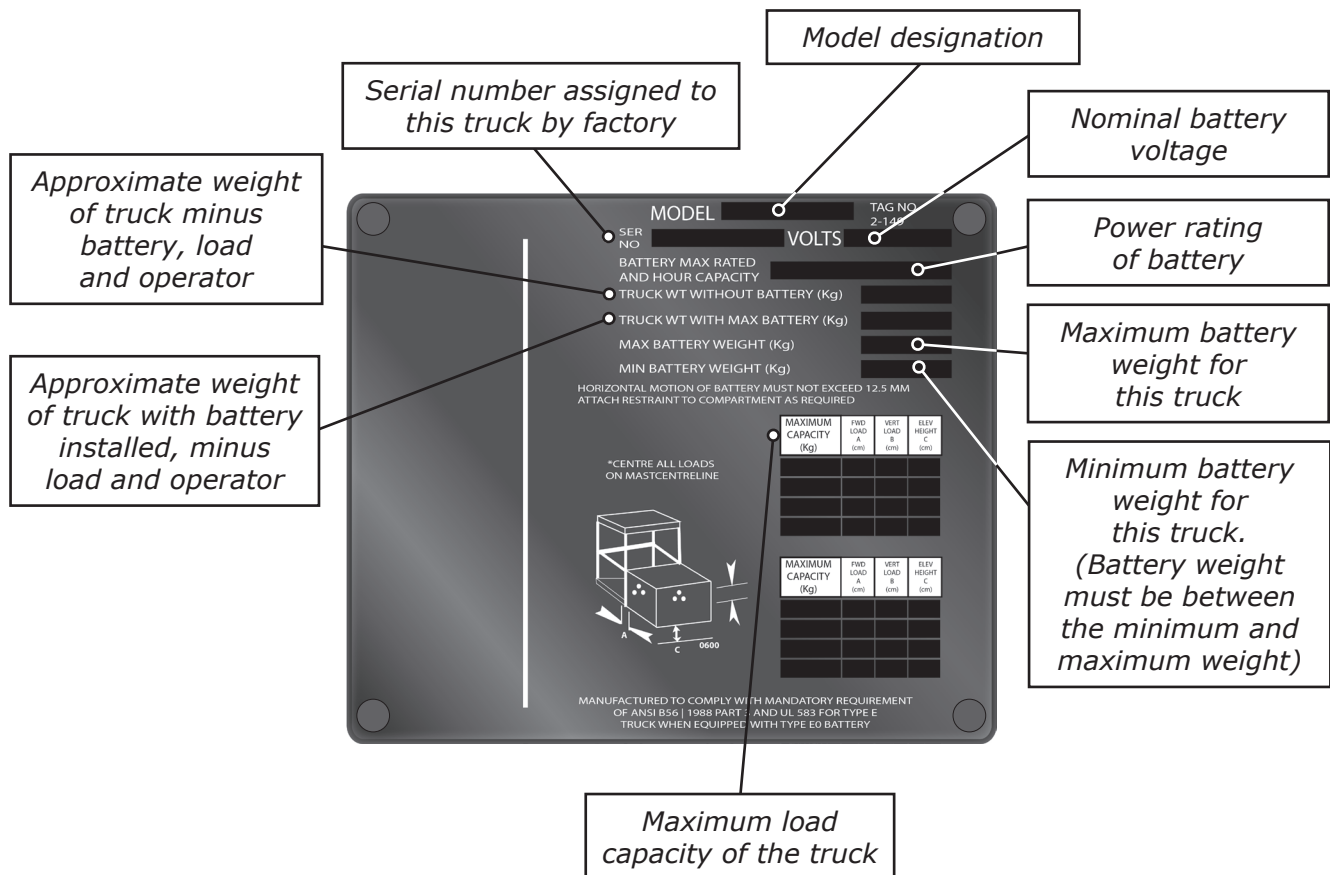

Part 1

Prepare for hazards



Trainers please note:

The answers in this book are in no way conclusive and are to be used as a guide only. Use your own knowledge and experience to correct the variation of answers that may be given by learners.

Performance Criteria: 2.3

Identify workplace hazards

A hazard is anything that can hurt you or others while you work. You need to know (identify) workplace hazards before you start work. Look for hazards. Look above you, look around you, and check the ground below you.



Theory Training Task 1

Performance Criteria: 2.3

a) Give examples of hazards you should look for before you begin work

Answers may include but not limited to:



Above head height

- powerlines and overhead service lines
- trees
- buildings
- other obstructions.

Ground level to eye level

- other equipment
- machinery/plant
- people and pedestrians
- things in the path of travel
- environmental conditions
- surrounding structures
- facilities
- dangerous materials
- other obstructions
- insufficient lighting.

Ground level (and below)

- stable/level surface
- spills or wet surfaces
- debris and rubbish
- trenched or recently filled trenches
- unstable ground
- underground services
- surface is strong enough to support the weight of any equipment/materials.



b) Tick any of these hazards you may have come across in past or present workplaces.

Trainers: Encourage your learners to place a tick beside hazards they have seen in their past or present places of employment.

Performance Criteria: 2.3, 3.1

Hazards control measures

What are hazard control measures?

They are actions you take to control or prevent a danger that can injure (hurt) you. Use controls to reduce the risk to workmates and property. Set up the hazard controls before you start the task.

The hierarchy of hazard control tells you the steps to take so you can reduce the danger from hazards.

A risk is the chance of a hazard injuring a person. In other words, what is the chance of the hazard hurting you?



Theory Training Task 2

Performance Criteria: 2.3, 3.1

a) What is a Job Safety Environment Analysis Worksheet (JSEA) used for?

A JSEA is used to record a work plan.

b) What else could you include to show how you will control a hazard?

A JSEA should include details of the:

- **Job**
- **Hazards**
- **Measures you will take to control those hazards.**

Job Safety Environment Analysis Worksheet			
Company name:	<input type="text"/>	Date:	<input type="text"/>
Site name:	<input type="text"/>	JSEA No.:	<input type="text"/>
Contractor:	<input type="text"/>	Permit to work requirement:	Yes <input type="checkbox"/> No <input type="checkbox"/>
Activity:	<input type="text"/>		

Part 2

Check the forklift



Trainers please note:

The answers in this book are in no way conclusive and are to be used as a guide only. Use your own knowledge and experience to correct the variation of answers that may be given by learners.

Performance Criteria: 2.6, 2.7

Visual check

Before you use an order picking forklift truck, do a visual check to make sure there aren't any problems.

Before you move any loads, look at the forklift to see if it's in a safe working condition and is right for the job.

A faulty forklift could cause an accident and injure or kill you or your workmates.



Theory Training Task 10

Performance Criteria: 2.6, 2.7



a) Circle the things you should check the order picking forklift for:

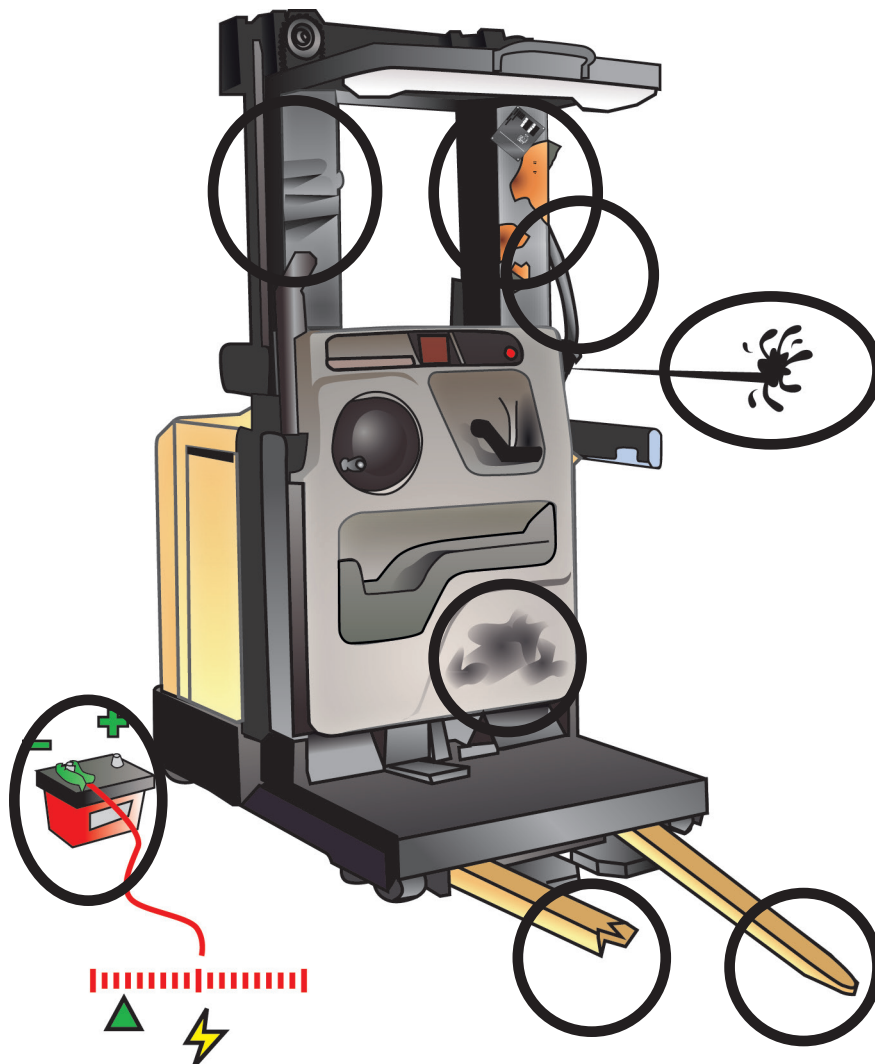

Part 3

Plan the move



Trainers please note:

The answers in this book are in no way conclusive and are to be used as a guide only. Use your own knowledge and experience to correct the variation of answers that may be given by learners.

Performance Criteria: 1.3

Choosing the right order picking forklift

Make sure you choose the right order picking forklift for where you are working.

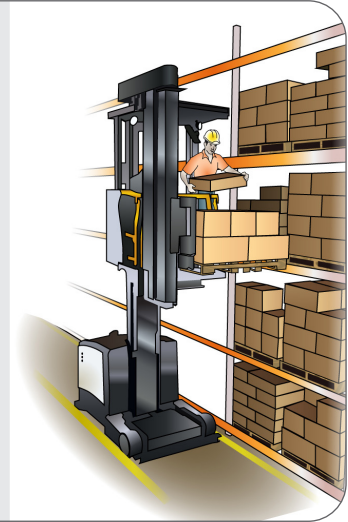

Theory Training Task 19

Performance Criteria: 1.3

a) How do you find out the order picking forklift's load capacity to make sure it can move or lift the load?

- By reading the order picker's load limits in the owner/operator manual
- By looking on the order picker's data plate.

b) Can you name three things an order picker's data plate tells you?

Answer may include:

- Maximum load capacity of the order picking forklift truck
- Load centre distance
- Approximate weight of order picking forklift truck
- Maximum lift height.

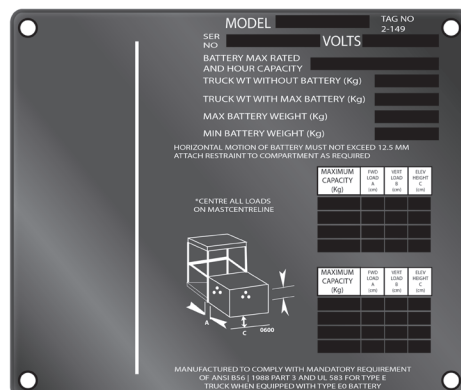

Performance Criteria: 1.4, 3.4

Check path of load

Check the route you will take to move the load.
Look out for hazards to avoid.



Theory Training Task 20

Performance Criteria: 1.4, 3.4

- a) When using an order picking forklift why do you need to keep to an agreed path?

So other workers know what you're doing.

- b) Why do you need to check the area **before** you start?

Answer includes:

- To plan the path I will move along.
- It also helps me choose the right order picking forklift to do the job.

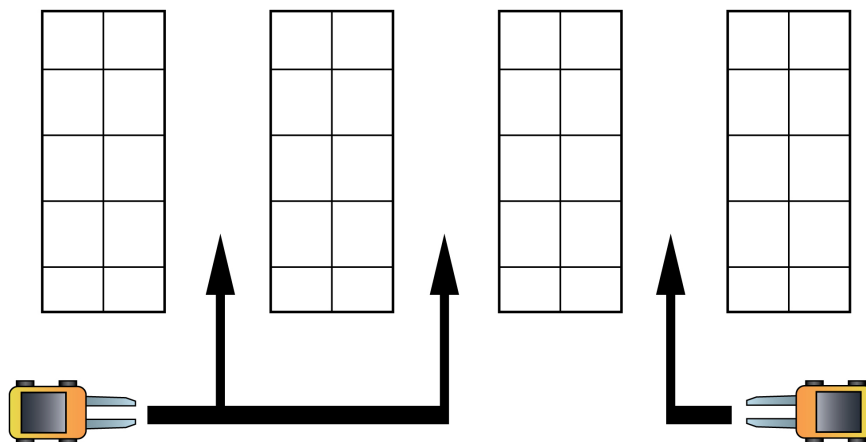

Part 5

Shut down and secure the order picking forklift



Trainers please note:

The answers in this book are in no way conclusive and are to be used as a guide only. Use your own knowledge and experience to correct the variation of answers that may be given by learners.

Performance Criteria: 3.8

Parking an order picking forklift truck

You have finished using the order picking forklift truck. Park it in a safe area so it won't get in the way of anything.

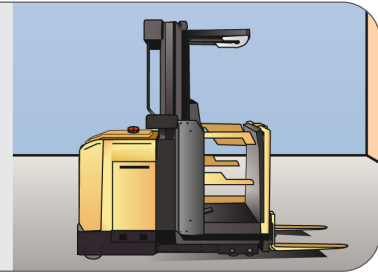

Theory Training Task 32

Performance Criteria: 3.8



Why is it dangerous to park an order picking forklift in front of an exit?

Answer may include:

- Parking in front of an exit will block it.
- If there is an emergency people will be unable to get out of the building.

Performance Criteria: 3.8

Shut down the order picking forklift

After you've parked the order picking forklift, you need to shut it down properly. Check the user/operator manual to learn the right shutdown procedure (things you should do).

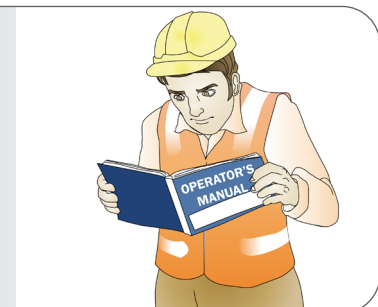

Theory Training Task 33

Performance Criteria: 3.8, 4.1

What should you do with the fork arms when you have finished using an order picking forklift truck?

The fork arms should be lowered with the fork tips resting on the ground.

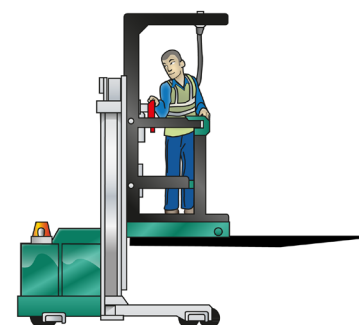



Theory Training Task 34

Performance Criteria: 4.1

Label the shutdown procedures below in the correct order from 1 to 4.

3



Turn the key switch to OFF/remove the keycard

4

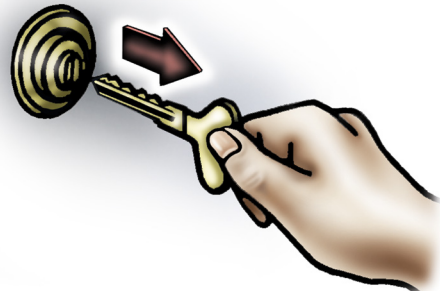

Take the key/keycard out of the ignition and disconnect the battery connector

2

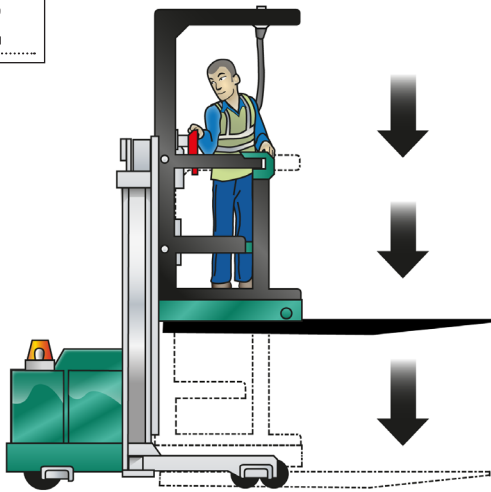

Lower the forks completely

1



Release the controls