

LEARNER GUIDE

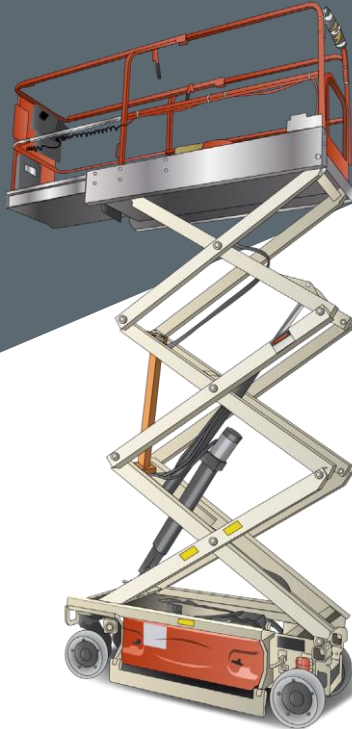

**This material is only intended for use with a Scissor lift
Includes question/answer and operational checklists**



EWP- Scissor Lift

RII COMPETENCY

Training support material for:

**RIIHAN301E –
Operate elevating work platform
(Scissor lift)**

Produced by:



This learner support material is designed to help trainees prepare for the requirements of the Units of Competency:

RIIHAN301E –

Operate elevating work platform (Scissor lift)

contained in the RII Resources and Infrastructure Industries Training Package.

Unit descriptor

This unit describes a participant's skills and knowledge required to operate an elevating work platform in the Resources and Infrastructure Industries.

This unit is appropriate for those working in operational roles.

Licensing, legislative, regulatory and certification requirements that apply to this unit can vary between states, territories and industry sectors. Relevant information must be sourced prior to application of the unit.

This material is only intended for use with a Scissor lift.

Edition 1: Version 2 – November 2020

We owe much thanks to input from numerous contributors and subject matter experts. Easy Guides Australia would like to acknowledge the valuable contribution of all those who have given us feedback and suggestions to develop and continue to improve the quality of this publication and related training products.

No part of this book may be reproduced or utilised in any form or by any means, electronic or mechanical, including photocopying, recording or by any information storage and retrieval system, without permission from the author and publisher.

Copyright penalty:

Section SNR20.1 of ASQA regulations states that an RTO in breach of copyright laws "may result in ASQA imposing sanctions on an RTO or the cancellation of a RTO's registration."

This book is a collaborative effort, designed and produced by:

Writer: Paul Wiles

Editors: James Tennant, Janelle Roberts

Graphic Designer/Desktop Publisher: Maree Herbert

Illustrators/3D Graphics: Nathan Leigh, Shirhan Manan

Disclaimer

All care has been taken to make sure this publication is accurate. The author and Easy Guides Australia Pty Ltd take no responsibility for any loss or damage resulting from any inaccuracies or omissions. Also, this publication does not foreshadow nor take responsibility for future changes to government laws, regulations and guidelines. All attempts have been made to make sure that the current publication is up to date at the time of publication. It is imperative that people working from these documents source relevant manufacturers' documentation and adhere to company, site and statutory procedures and requirements. This publication is a learning tool only. Ultimately, it is the accredited assessor working through the registered training organisation who will determine if a candidate is competent.

Contents

How to use this guide	4
Language – Literacy – Numeracy (LLN)	5
Introduction to scissor lift	7
Element 1 Plan and prepare for operating an elevating work platform	18
Element 2 Operate elevating work platform	75
Element 3 Conduct housekeeping activities	147
Practical training record	156
Operating record	165

About this guide

The guide is a follow-up to your formal training.

Like all Easy Guides, this one uses plain words and pictures to help you remember what you learned in your formal training. So you can pass your test – and achieve competency.

Good luck from the team at Easy Guides Australia Pty Ltd.

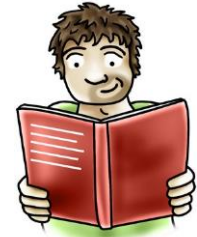

Easy Guides training materials have been developed around Language – Literacy – Numeracy (LLN) principles.

How to use this guide

Use it in hard copy

This guide helps you prepare for the test at the end of the course. Study it carefully, and then ask a friend to help you practise. They can ask you each question, and then you give the answer. Writing down the answers can also help you remember them. This also helps you see what you still need to learn. Good luck!

Or use it on screen

This guide also comes in a multimedia presentation, so you can use it on your computer or screen. The multimedia presentation is just like the guide and has exactly the same questions with the same short words and easy-to-understand pictures.

Trainers can use the multimedia presentation in class to help learners discuss questions. The trainer first shows the question and asks if anyone knows the answer. Next, the trainer will show the answer and discuss it with the learners.

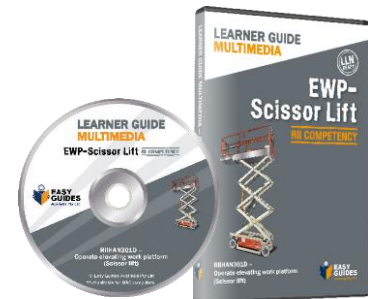
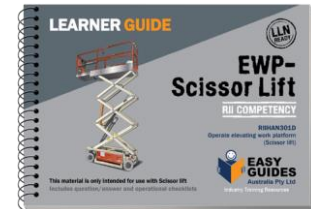

Language – Literacy – Numeracy (LLN)

TAELLN411 Address adult language, literacy and numeracy skills

Why LLN matters?

The unit **TAELLN411 Address adult language, literacy and numeracy skills** describes the skills and knowledge a vocational trainer or assessor requires to identify language, literacy and numeracy (LLN) skill requirements for training in the work environment. The aim is to use resources and strategies that meet the needs of the learner group.

The LLN unit applies to individuals who teach, train, assess and develop resources.



Easy Guides training materials have been developed around LLN principles

James Tennant, Managing Director of Easy Guides Australia Pty Ltd has completed the LLN unit as well as a MA (TESOL) Masters of Arts degree in teaching speakers of other languages.

James taught as a Workplace language and literacy (WELL) teacher in industry where he gained knowledge and experience for adapting training to a wide range of learners.

James' qualifications and experience have been embedded into the Easy Guides training materials making them unique in their field.



LLN core skills – customising training

The Australian Core Skills Framework (ACSF) provides a detailed description of each of the five core skills which help people to participate effectively in our society.

The core skills are:



Trainers can use knowledge of the core skills of their learners to adjust their training program. For example, a learner may be high in oral communication but low in writing.

For such learners, training materials could:

- be written in simple, plain English
- use pictures and diagrams to explain concepts
- use bullet points or tables instead of long paragraphs
- explain difficult words that students might need to know.

Easy Guides has built many of these LLN learning strategies into their training materials.

Introduction to Scissor lift

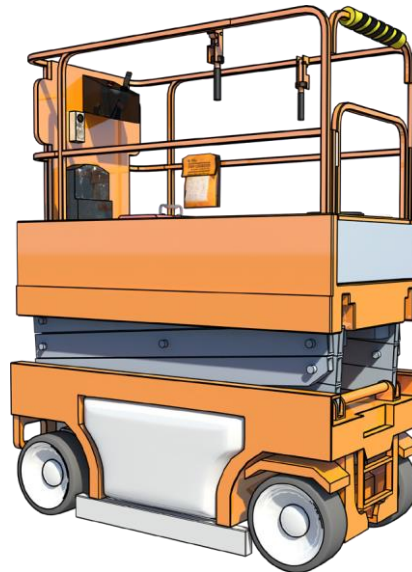

Parts of a scissor lift

Types of scissor lifts

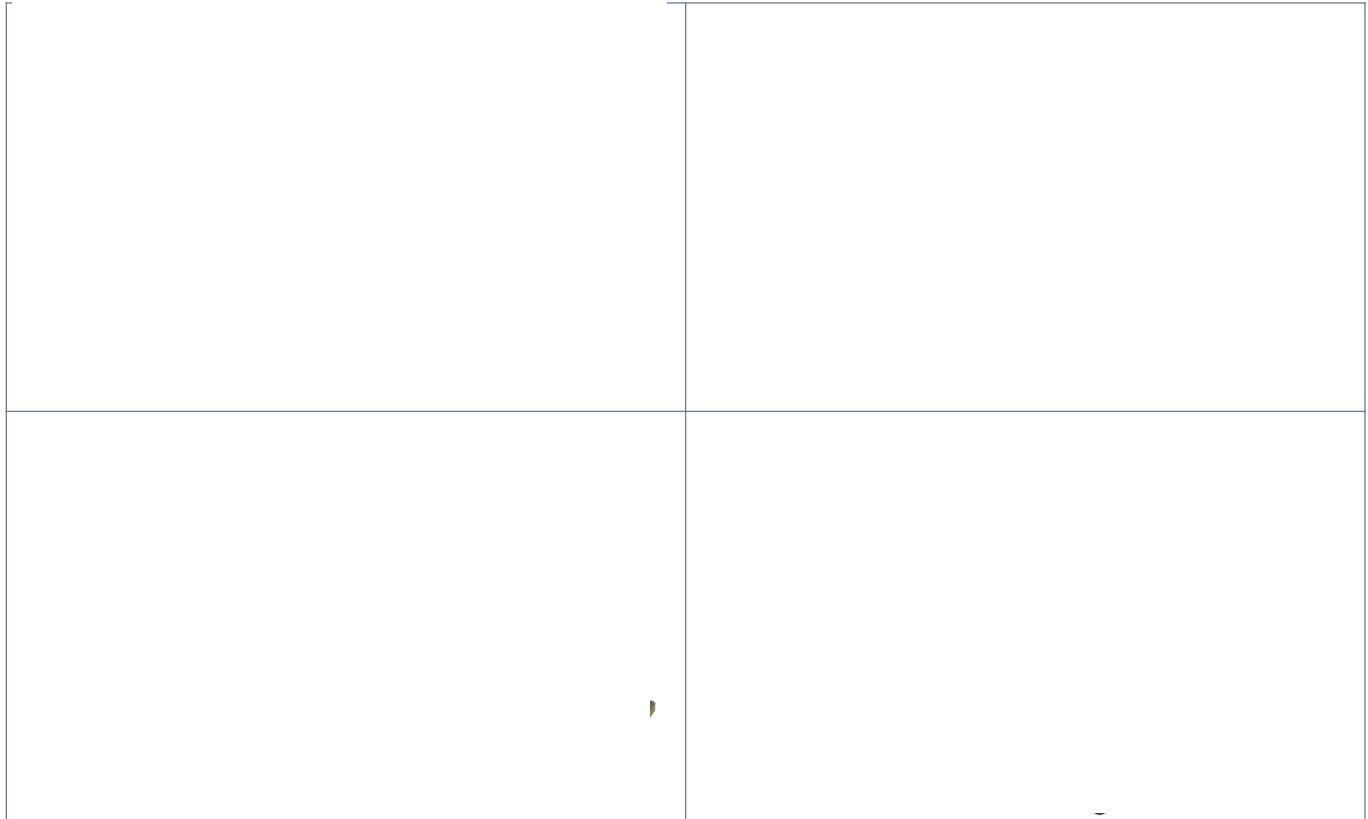

Types of scissor lifts (continued)

--	--

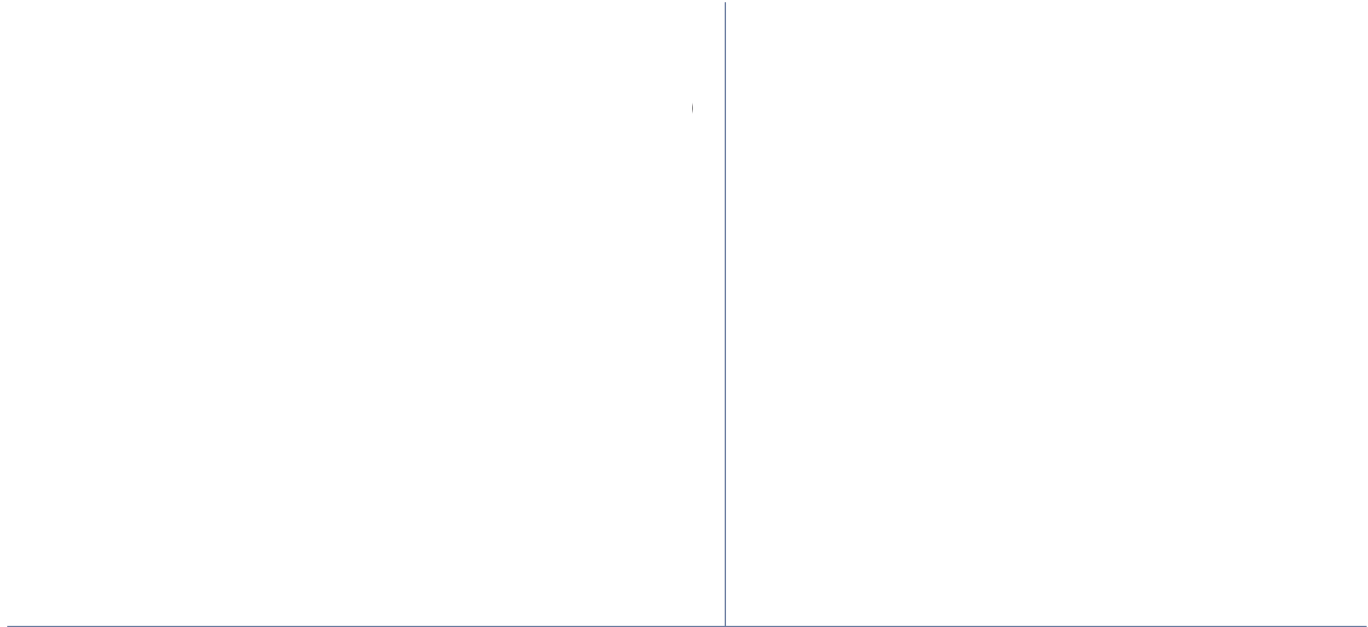



QUESTION 1

Blank area for writing the answer to Question 1.

Blank area for writing the answer to Question 1.

QUESTION 2

Blank area for writing the answer to Question 2.

Blank area for writing the answer to Question 2.

QUESTION 3

Blank area for writing the answer to Question 3.

Blank area for writing the answer to Question 3.

Blank area for writing the answer to Question 3.

Blank area for writing the answer to Question 3.

Blank area for writing the answer to Question 3.

QUESTION 4

Blank area for writing the answer to Question 4.

Blank area for drawing or diagram related to Question 4.

Blank area for drawing or diagram related to Question 4.

Plan and prepare for operating an elevating work platform

Element 1

