

# POWERPOINT PRESENTATION

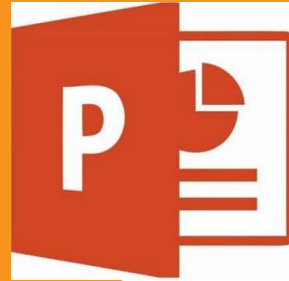

## Scaffolding - Basic LICENCE

CPCCLS2001

Licence to erect, alter and  
dismantle scaffolding basic level



**EASY  
GUIDES**

Australia Pty Ltd

# Introduction to basic scaffolding



## What is basic scaffolding?

### Parts of basic scaffolding

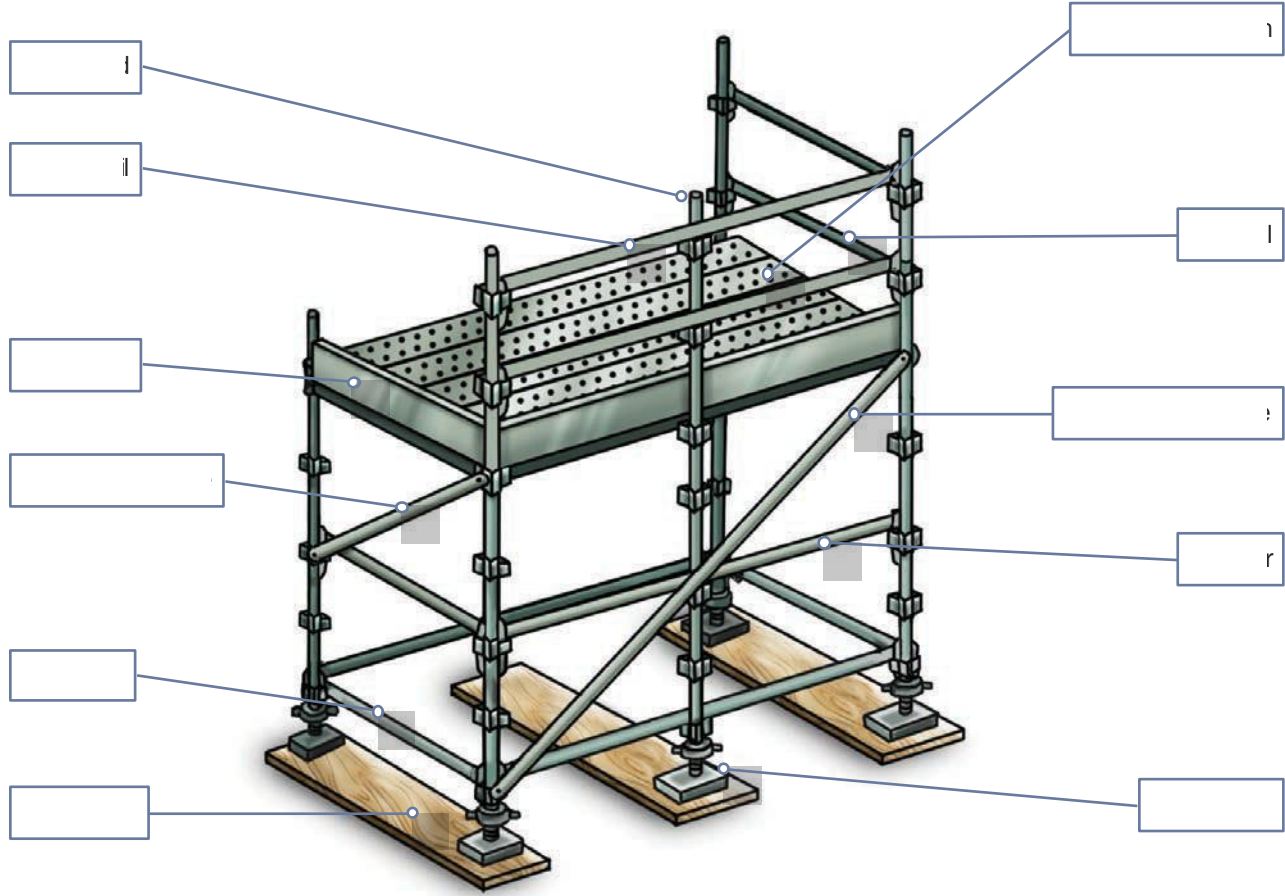

# Explanation of dead weight/load

...CONTINUED FROM PREVIOUS PAGE

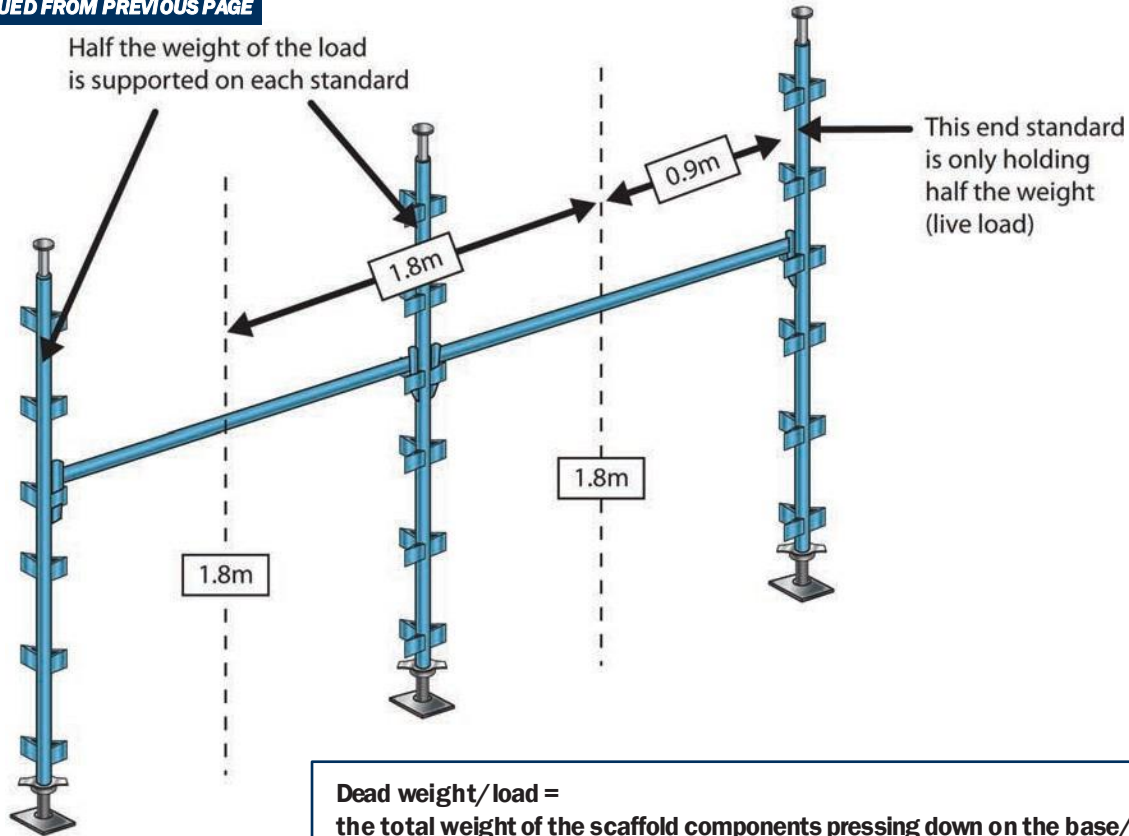

**QUESTION 30**

**...CONTINUED FROM PREVIOUS PAGE**

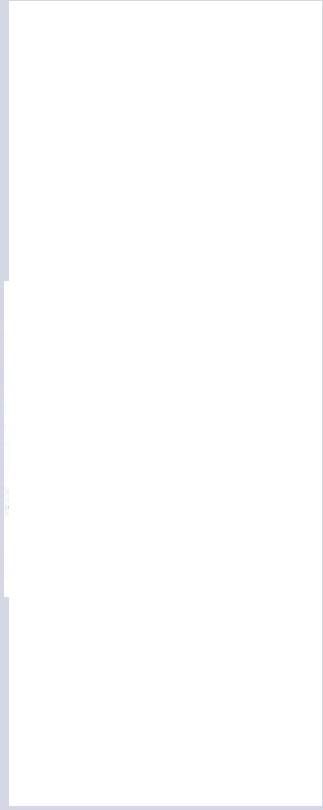

**...CONTINUES ON NEXT PAGE**

**QUESTION 30**

**...CONTINUED FROM PREVIOUS PAGE**

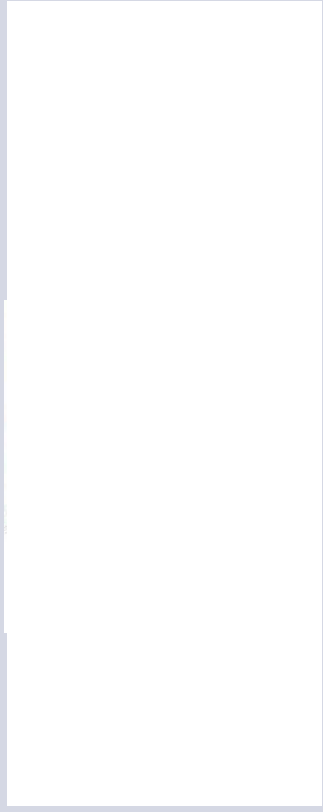

**...CONTINUES ON NEXT PAGE**

## Explanation of live load

---



**QUESTION 30**

***...CONTINUED FROM PREVIOUS PAGE***

