

INFORMATION BOOK



Rigging - Intermediate

LICENCE

Training support material for:

Licence to perform rigging intermediate level

Produced by:



Includes training tasks

Contents

How to use this guide	4
Language – Literacy – Numeracy (LLN)	5
Acknowledgements	7
Introduction to intermediate rigging	9
High risk licensing and the law	21
Element 1 Plan job	31
Element 2 Select and inspect equipment	79
Element 3 Set up tasks	101
Element 4 Erect structures and plant	139
Element 5 Dismantle structures and plant	161
Test yourself – Learning tasks	191
Operating record	205

Introduction to Intermediate rigging

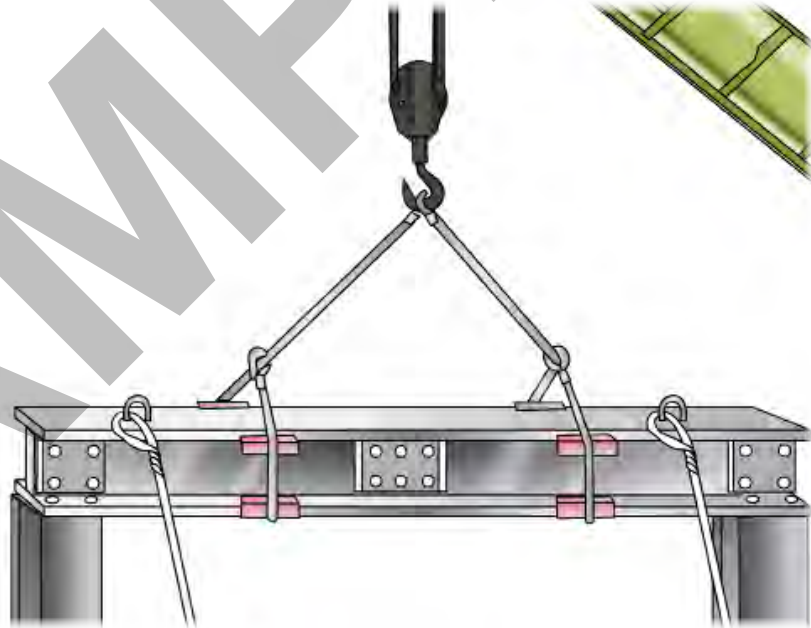

What is intermediate rigging?

Intermediate rigging is the name given to a number of tasks such as:

Erection or altering cranes, conveyors, dredges and excavators on site.



Erection or altering the rigging of a crane to lift particular loads.



Erection or altering the rigging of a crane to access load positions.



Erection or altering the crane hoist rope configuration to suit the load weight to be lifted.



Dismantling of cranes on site



Rigging of cantilevered platforms (personnel and materials hoist)

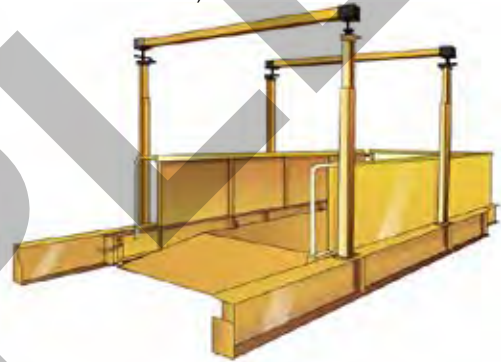

Rigging hoist with jibs



Rigging tower cranes



What is intermediate rigging (continued)

Lifting and rotating tilt panels

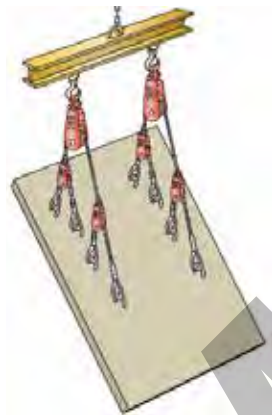

Dual lifts

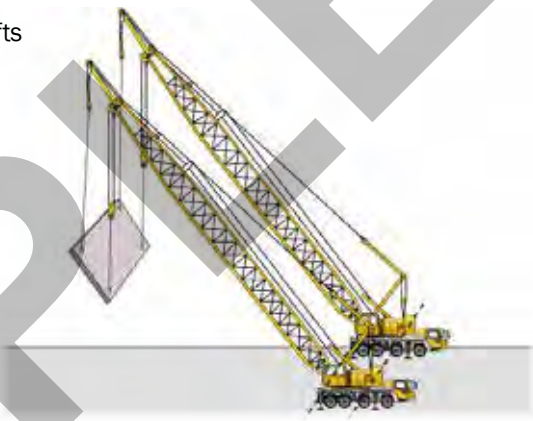

Lifts using load equalising gear

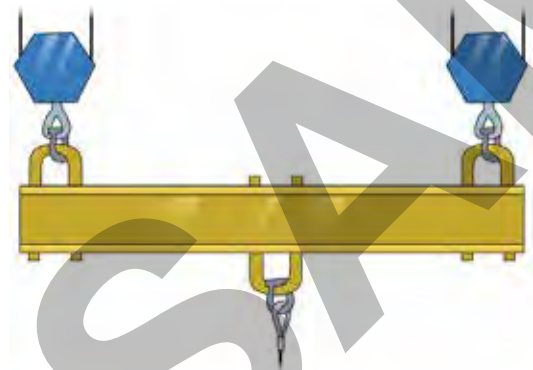

Demolition of structures



Common tasks

Common tasks undertaken by a person with a licence to perform high risk work as an intermediate rigger include:

Rig cranes to suit work required



Erection of cranes, conveyors, dredges and excavators

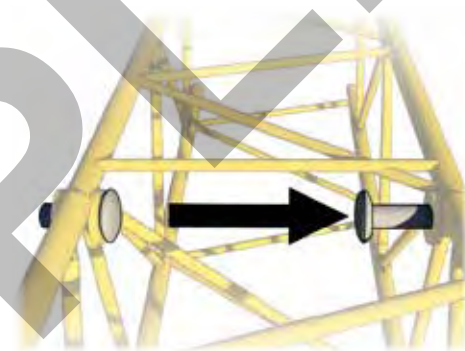

Erection of tilt slabs

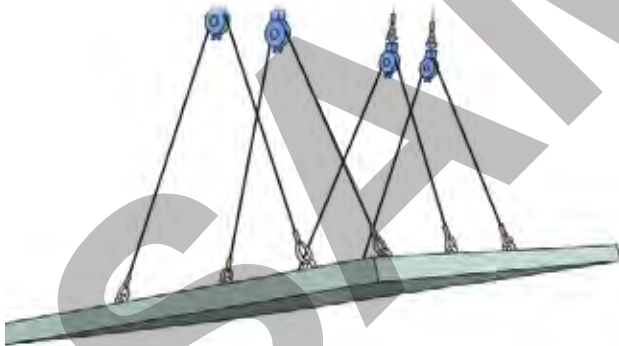

Demolition of structures or plant

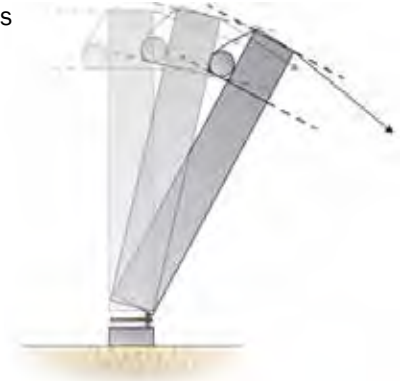

Common tasks (continued)

Lifts using load equalising gear

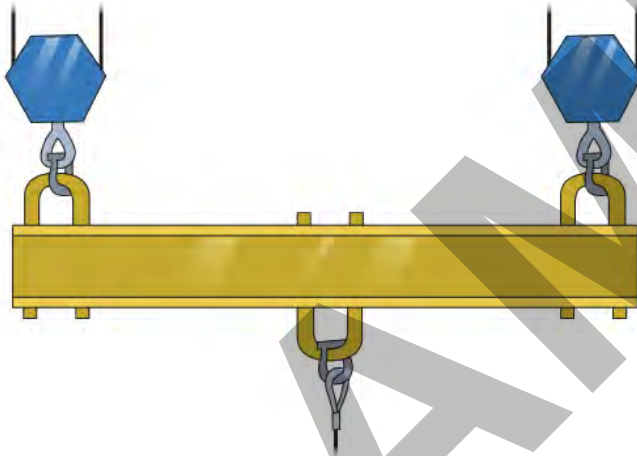

Dual lifts (lifts using more than 1 crane or a crane and another lifting device such as a winch).

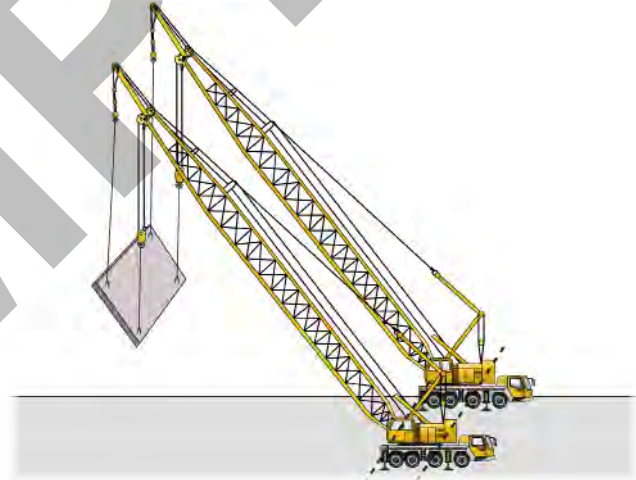

An intermediate rigger can also perform work usually done by a dogger or basic rigger such as:

The application of slinging techniques



Selection and inspection of lifting gear, to safely sling a load



The directing of a plant operator in the movement of a load when the load is out of the operator's view

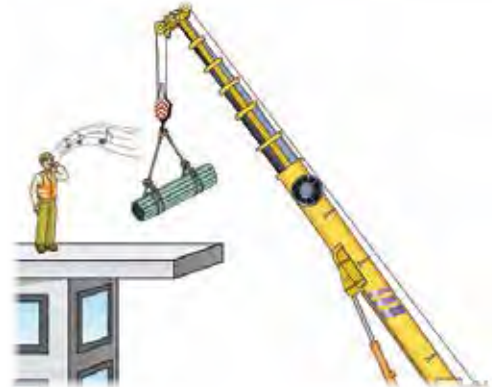

An intermediate rigger can also perform work usually done by a dogger or basic rigger (continued)

Deciding on the type of lifting gear and checking it's condition (or checking it's safe).



Deciding the slinging method by considering the type of load, its mass and centre of gravity.



An intermediate rigger can also perform work usually done by a dogger or basic rigger (continued)

Rigging work involving:

Structural steel erection



Hoists



Pre-cast concrete members of a structure



Safety nets and static lines

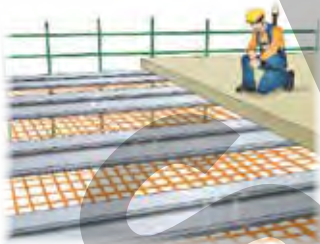

Mast climbing work platforms



Perimeter safety screens and shutters



Cantilevered crane loading platforms



An intermediate rigger **cannot perform any rigging work** involving any of the following.

Gin poles



Shear legs



Flying foxes and cable ways



Guyed derricks and structures



Suspended scaffolds



Fabricated hung scaffolds

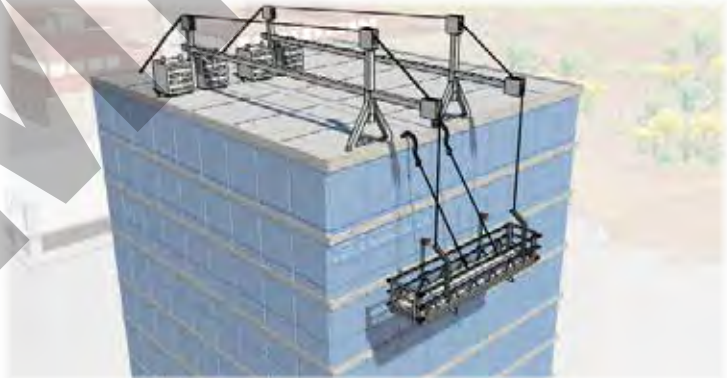

Note:
These tasks must be performed by an Advanced Rigger.