

Trainer Value Pack

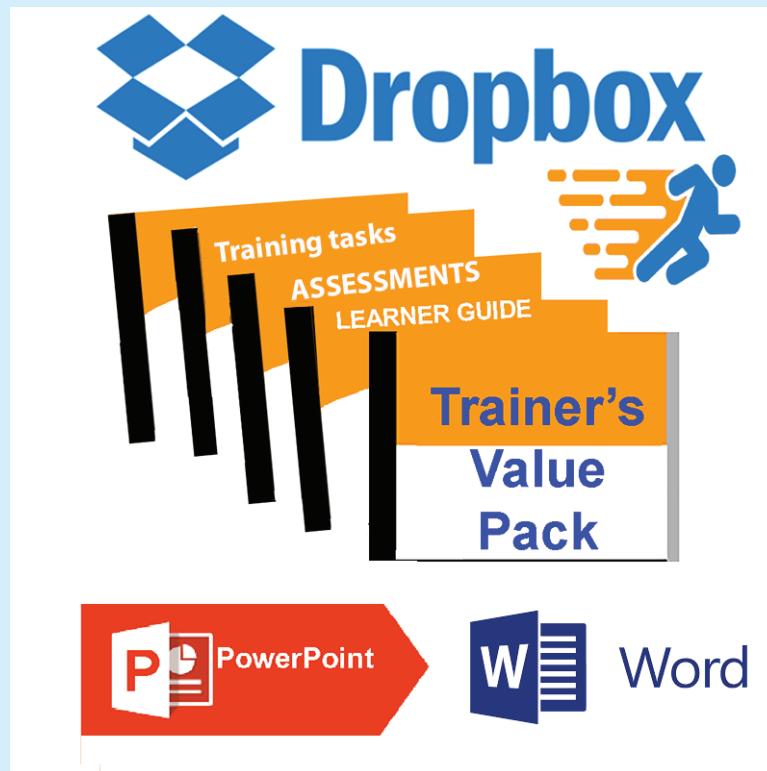

The benefits of using a Trainer Value Pack



1. All materials are fully mapped to the unit of competency.
2. **Audit Guarantee.** If a government auditor finds any non-conformance with our products then we'll fix them for FREE.
3. Picture based materials make learning easy.
4. Materials can be printed and customised to suit your needs.

The benefits of using the Safety and Licence Guide

FORKLIFT TRUCK **SAFETY AND LICENCE GUIDE**



Training support material for:

TLILIC0003
Licence to operate
a forklift truck

Produced by:



PICTURE BASED. PLAIN ENGLISH. LEARNING MADE EASY.

1. Contains the knowledge needed to pass the national forklift truck test.
2. Pictures make learning easy.
3. The Question & Answer approach make a great learning tool.

FORKLIFT TRUCK

SAFETY AND LICENCE GUIDE



Training support material for:

TLILIC0003

Licence to operate
a forklift truck

Produced by:



PICTURE BASED. PLAIN ENGLISH. LEARNING MADE EASY.

INTRODUCTION TO FORKLIFT TRUCKS

What is a forklift truck?

A forklift is a powered industrial truck used to lift and move loads. It has a mast and an elevating load carriage with a pair of fork arms or other load-holding parts. As you can see below, there are different types of forklifts. The most common forklift is the counterbalance forklift truck.

This series of images were used with permission from Linde

Counterbalance forklift truck



Order picking forklift truck (LO licence)



Walkie reach stacker



Rough terrain forklift truck



Narrow aisle turret truck (Lo licence)



Sit-on reach forklift truck



Counterbalance forklift

The most common forklift is the counterbalance type. This means they carry the load on the front mounted forks (tynes) and use all the weight behind the front wheels to counterbalance the load.

The point of balance on a forklift is called the **fulcrum**. The fulcrum is where a vertical line drawn through the centre of the front axle would meet the ground. An easy way to remember this is the fulcrum is where the front wheels touch the ground.

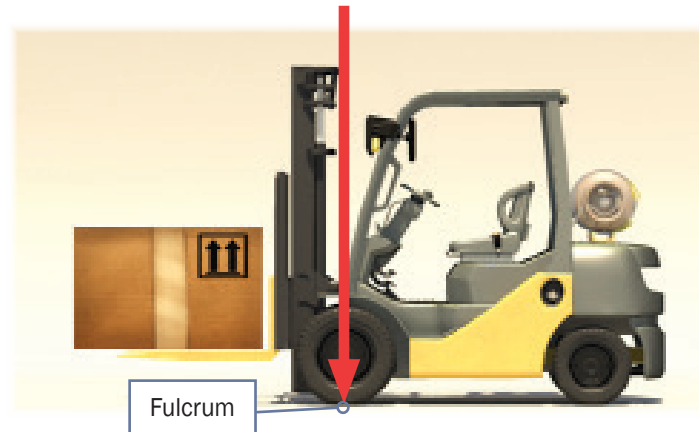

Everything behind the fulcrum acts as a counterweight.

Think of the forklift as being like a see-saw. If you have more weight than counterweight the forklift will tip forwards.

You cannot add more counterweight to try to lift a heavier load. Forklifts are not designed for this. If you did this you could damage the forklift.



Parts of a forklift truck

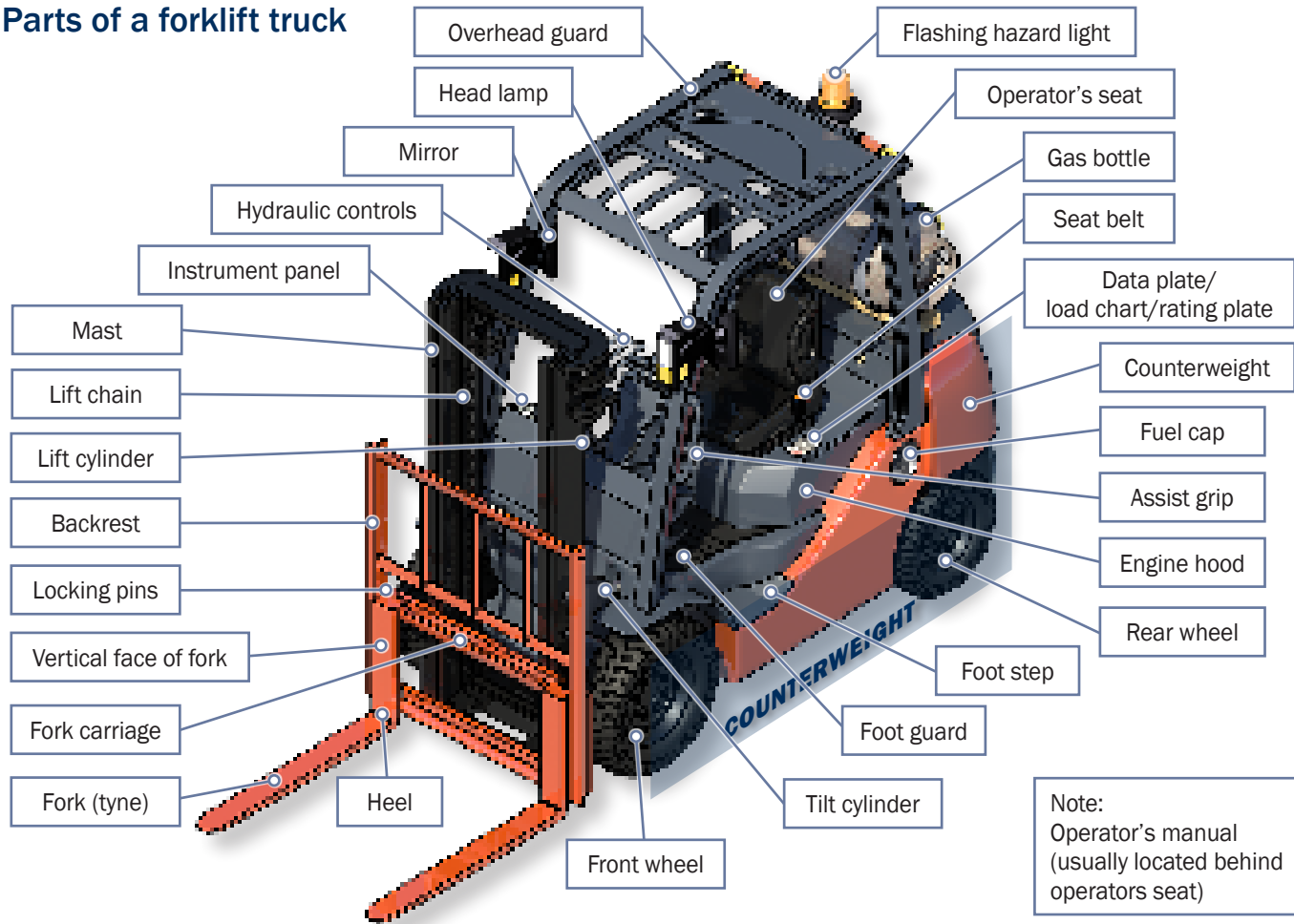

QUESTION 1

A forklift has a point of balance (fulcrum).

Where is it?

The fulcrum (point of balance) is at the bottom of the front tyre.
It is the point where the front tyre touches the ground.

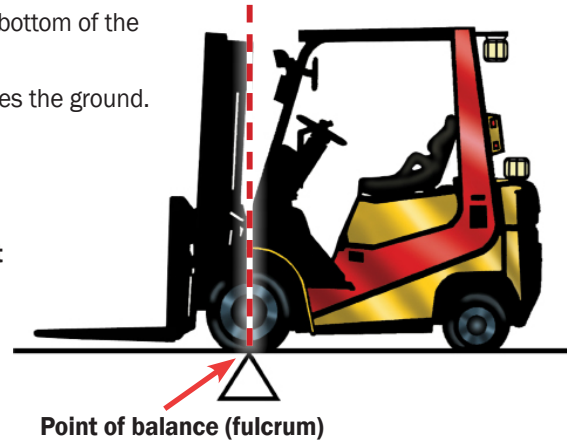
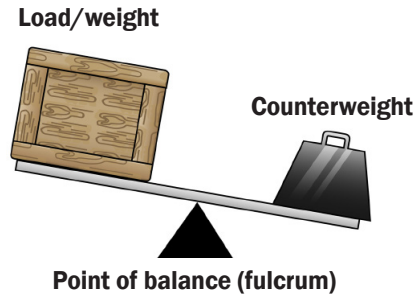

QUESTION 2

Does all of the weight behind the point of balance work as a counterweight?

Yes. All the weight behind the point of balance acts as a counterweight.

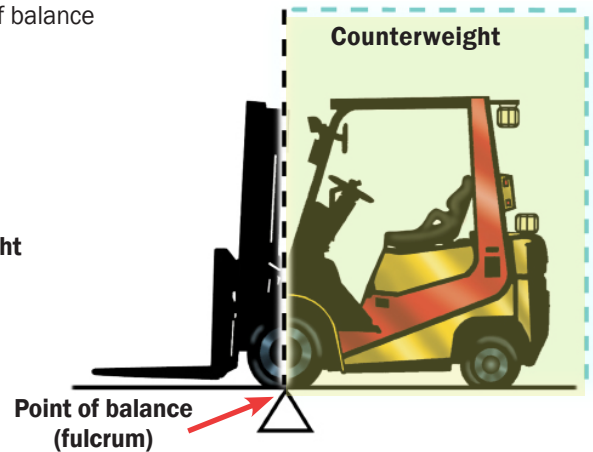
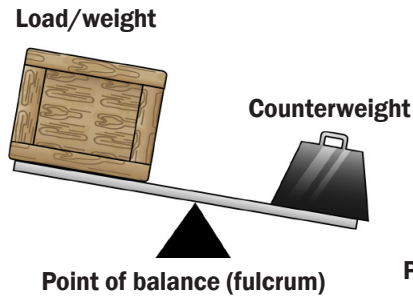

QUESTION 3

Are you allowed to put more counterweight on a forklift without checking the manufacturer's instructions?

No. Forklifts are made to lift specific maximum loads.

Changing the counterweights could cause an accident.

FORK TRUCK LOAD AND WARNING NOTICE			
Operators must be trained and authorised. Do not operate the lift truck if it is in need of repair. This capacity plate is not transferable and is invalidated by any change to specifications.			
MODEL:	A12345A	SNO:	123456
MAST/CARRIAGE TILT DEGREES:	TYRE PRESSURES KPA:		
FORWARD/DOWN:	6	FRONT:	686
BACK/UP:	12	REAR:	686
DRIVE WHEELS:	SINGLE	TYRE TYPE:	PNEUMATIC
TRACTION BATTERY WEIGHT (KG) MIN:	N.A.	MAX:	N.A.
TARE WEIGHT WITHOUT TRACTION BATTERY (KG):	2745	HIRF:	921
RATED CAPACITIES - SIDESHIFT & LOAD IN CENTRE POSITION			
	LOAD CENTRE (MM)	LIFT/LOAD HEIGHT (MM)	MAST VERTICAL CAPACITY (KG)
SIDESHIFT	600	3700	1575
			MAST FORWARD CAPACITY (KG)
			900
PLATE I.D.:	12345	DEALER:	EASY GUIDES PTY LTD

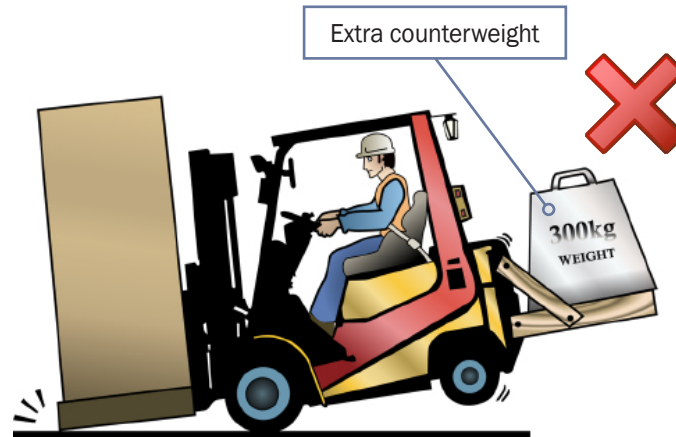

ELEMENT 1

PLAN WORK/TASK

Hazards – indoors

Before you begin work, you must be aware of hazards. A **hazard** is any thing or situation with the potential to cause injury or harm. In other words it is any 'thing' or 'action' that can hurt you or other workers.

If you are working indoors you must think about things like:

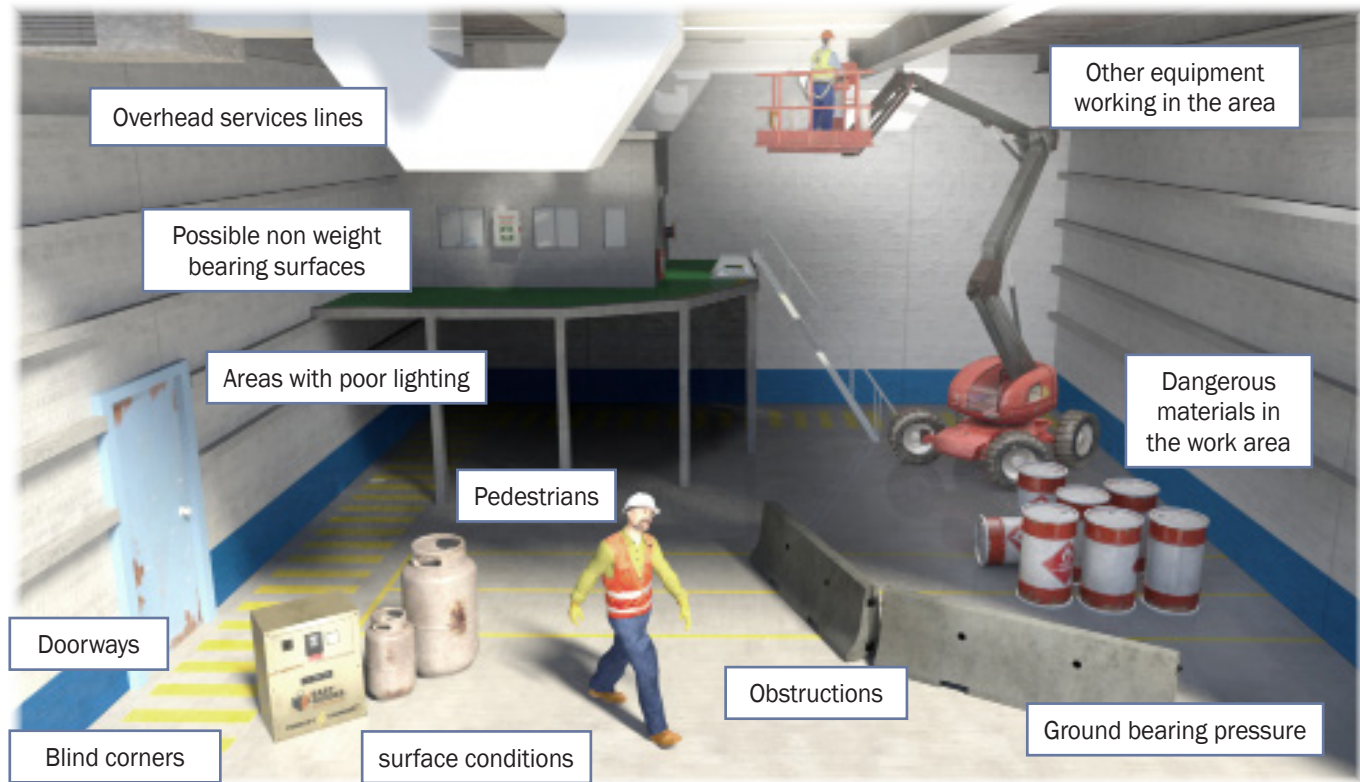

Suitability of forklift and attachment

Every forklift has a data plate. You must check the data plate before using the forklift. The data plate tells you important things about the forklift. This includes telling you how much the forklift can safely lift and what attachments you can use.

The data plate helps you work out if the forklift and attachment are suitable for the load.

Make and model of the forklift

Serial number

Attachment type

Load centre distance

Maximum lift height

Forklift weight

Rated capacity - both vertical and tilt

WARNING
 USE OF FORK LIFT TRUCKS, GRABS, SLIPPERS OR JIB

1. NEVER CLIMB OR OVERLEAP MARKS
2. DO NOT LIFT LOADS UNLESS PLACED FIRMLY ON FLOOR
3. DO NOT TRANSPORT OR MANEUVERE WITH LOAD RAISED ABOVE SHOULDER HEIGHT TO CLEAR OBSTRUCTIONS AND THIS OUTLET MUST BE KEPT BACK THROUGHOUT
4. DO NOT PUT BACK FORWARD EXCEPT WHERE NECESSARY TO PICK UP OR DEPOSIT A LOAD
5. DO NOT WALK WITH ANY LOADS UNLESS YOU'RE SEATED IN THE SEAT
6. DO NOT REVERSE UNLESS YOU HAVE CONTROLLED YOUR LOAD
7. CENTRALISE BRAKE ARM ON PARKING BRAKE BEFORE LIFTING
8. DO NOT PUT BACK FORWARD UNLESS YOU STOPPED ON JOB
9. DO NOT OPERATE AS POSSIBLE AT ALL TIMES BY USING MINIMUM CAPACITY LEVELS OF LIFTING RIGID
10. ALWAYS USE ATTACHMENT UNLESS THE ALLOWABLE

RATED CAPACITIES - SIDESHIFT & LOAD IN CENTRE POSITION

	LOAD CENTRE (mm)	LIFT HEIGHT (mm)	MAX. NETICAL CAPACITY (kg)	MAX. TYPICAL CAPACITY (kg)
SIDESHIFT	600	3700	1675	900

MANUFACTURER: NISSAN MOTOR Co. LTD. TOKYO JAPAN
 NISSAN FORKLIFTS: POWERLIFT NISSAN PTX LIMITED SYDNEY A/CN 80031501 Ph: 61 2 9771 2608
 PLATE I.D.: 00 07 091 DENIER: N-22693-1
 WHERE FITTED - USE THE SEAT BELT

Checking the rated capacity

Check the data plate to find the rated capacity.

The forklift with the following data plate attached has the rated capacity of:

1575 kg with a **sideshift attachment** lifting a load to a **3700 mm height** with **vertical mast** and a **600 mm load centre**

OR

900 kg with a **sideshift attachment** lifting a load to a **3700 mm height** with **forward tilted mast** and a **600 mm load centre**



FORK TRUCK LOAD AND WARNING NOTICE

Operators must be trained and authorised. Do not operate the lift truck if it is in need of repair. This capacity plate is not transferable and is invalidated by any change to specifications.

MODEL:	A12345A	S/NO:	123456	MAST:	2W370
MAST/CARRIAGE TILT DEGREES:		TYRE PRESSURES KPA:			
FORWARD/DOWN:	6	FRONT:	686		
BACK/UP:	12	REAR:	686		
DRIVE WHEELS:	SINGLE	TYRE TYPE:	PNEUMATIC		
TRACTION BATTERY WEIGHT (KG) MIN:		N.A.	MAX:	N.A.	VOLT: N.A.
TARE WEIGHT WITHOUT TRACTION BATTERY (KG):		2745	921		

RATED CAPACITIES - SIDESHIFT & LOAD IN CENTRE POSITION

	LOAD CENTRE (MM)	LIFT/LOAD HEIGHT (MM)	MAST VERTICAL CAPACITY (KG)	MAST FORWARD CAPACITY (KG)
SIDESHIFT	600	3700	1575	900

PLATE I.D.:	12345	DEALER:	EASY GUIDES PTY LTD
-------------	--------------	---------	----------------------------

Load centre distance

Load centre distance is the **distance measured from the vertical face of the forks to the centre of gravity of the load.**

The load centre distance affects how much weight the forklift can lift.

The load centre distance will be marked on your forklift's data plate.

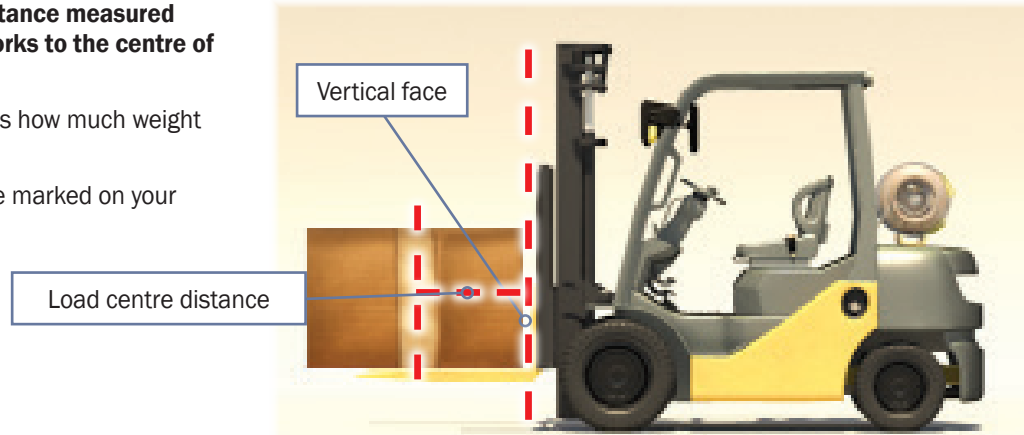

For example, this forklift is lifting a 1500 kg load.

The forklift rated capacity is **1575 kg** at a **600 mm load centre distance.**

It's okay to lift this weight.

But the load centre distance must be checked to make sure it is 600 mm or less first. 600mm is the most common load centre distance in millimetres.



The benefits of using the Learner Workbook

FORKLIFT TRUCK LEARNER WORKBOOK

TLILIC0003

Licence to operate a forklift truck



www.easyguides.com.au



Learner name: _____

Student number: _____

Date: _____

1. Helps students to apply what they are learning.
2. Contains knowledge and practical training tasks.

FORKLIFT TRUCK LEARNER WORKBOOK

TLILIC0003

Licence to operate a forklift truck



www.easyguides.com.au

National Licence
RTO-VET Learning Materials

Contents

Language – Literacy – Numeracy (LLN)	4
How to get the most out of this book	5
Things to consider when learning.....	6
Learning support materials	7
Learning and practical tasks.....	8
What is a forklift truck?	9
Basic forklift concepts	10
Introduction to high risk licensing	13
New National Vocational Education and Training (VET) licensing pathway	14
Training and assessment requirements	15
Record of training logbook	16
Who has a duty of care?	17
Where to find licensing information	18
Introductory training exercise	19
Chapter 1—Plan Work	23
Practical Task 1	47
Practical Task 2	49
Chapter 2—Conduct Routine Checks	53
Practical Task 3	71
Chapter 3—Shift Load	73
Practical Task 4	99
Chapter 4—Shut Down and Secure Forklift Truck	101
Practical Task 5	109
Thank you	111
Continuous improvement form	112

What is a forklift truck?

A forklift is a powered industrial truck used to lift and move loads. It has a mast and an elevating load carriage with a pair of fork arms or other load-holding parts.

As you can see below, there are different types of forklifts. The most common forklift is the counterbalance truck.



Counterbalance forklift truck

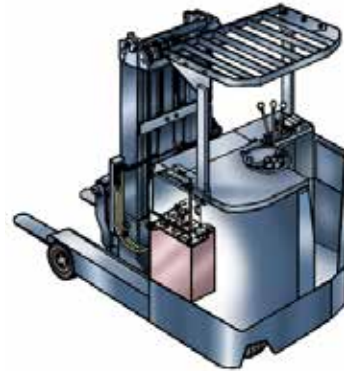

**Reach truck
(non-counterbalance) forklift**

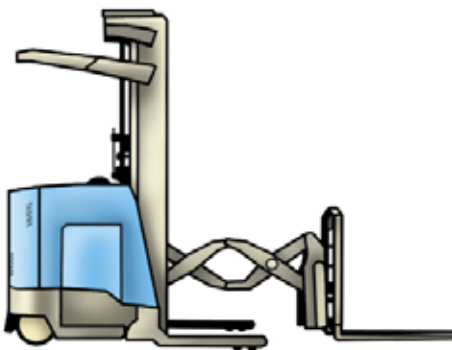

Double-deep reach truck



Truck mounted forklift truck



Rough terrain forklift truck



Articulated narrow aisle forklift truck

Basic forklift concepts

Point of balance (fulcrum)

The most common forklift is the counterbalance type.

This means they carry the load on the front mounted tynes and use all the weight behind the front wheels to counterbalance the load.

The point of balance on a forklift is called the fulcrum. Think of it as a vertical line through the axle of the front wheel, where the line meets the ground.

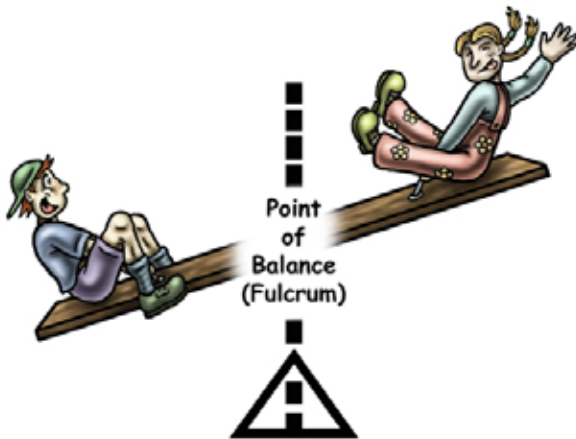
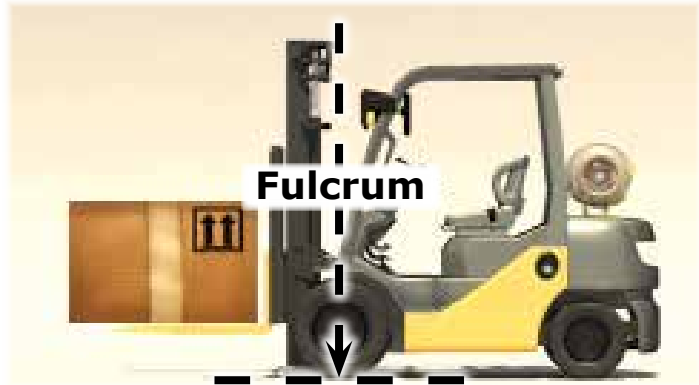

Think of a counterbalance forklift truck as being like a see-saw. If you put too much weight on one end it tips over.

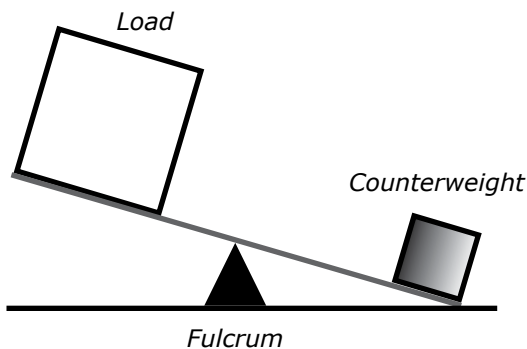

All the weight behind the point of balance acts as a counterweight.

Plan Work



Performance Criterion: 1.5

Identify workplace hazards

A hazard is anything that can hurt you or others while you work.

You need to know (identify) workplace hazards before you start work.

Look for hazards.

Look above you, look around you, and check the ground below you.





Theory Training Task 1

Performance Criterion: 1.5

a) Give examples of hazards you should look for **before** you begin work.

Above head height

.....

.....

.....

.....

.....

.....

.....

.....

.....

.....

.....

Ground level to eye level

.....

.....

.....

.....

.....

.....

.....

.....

.....

.....

.....

Ground level (and below)

.....

.....

.....

.....

.....

.....

.....

.....

.....

.....

.....



b) Tick any of these hazards you may have come across in past or present workplaces.



Theory Training Task 2

Performance Criterion: 1.5

- a) Circle all the hazards (dangers) you can find in the picture below.

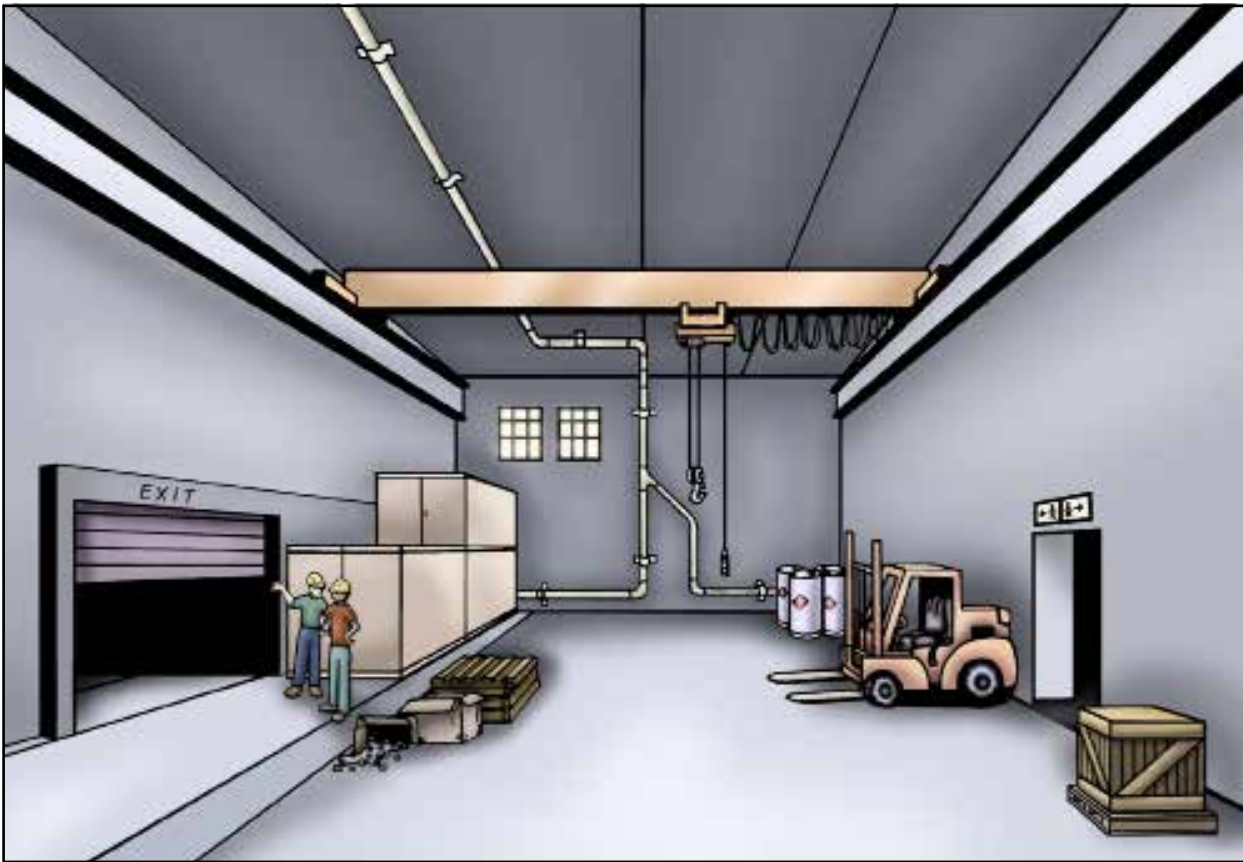

- b) How could the people in this picture be a hazard if you were using a forklift near them?

.....

.....

.....



- c) Can you think of ways to ensure these people do not get in the way of the forklift?

.....

.....

.....

.....

.....



Theory Training Task 5

Performance Criterion: 1.5

a) What is rear-end swing?

.....
.....

b) Who do you think is most at risk from forklift rear-end swing?

.....



Theory Training Task 6

Performance Criterion: 1.5

a) Circle which would be considered an enclosed or poorly-ventilated area.

freezer

carpark

shed

cold storage room

b) Why do you think you shouldn't use a petrol forklift truck in a small freezer room?

.....
.....



Theory Training Task 7

Performance Criterion: 1.5, 2.3

Check the safe working distances for powerlines in your state or territory. How many metres is the NO GO zone for distribution lines on poles in your state or territory?

The NO GO zone for

..... (state/territory)

is metres.





Theory Training Task 8

Performance Criterion: 1.2, 1.5, 2.3

a) What kind of forklift truck do you use on rough ground?

.....

b) Where can you find out more information about the right forklift to use?

.....



Theory Training Task 9

Performance Criterion: 1.5, 2.3

What is the recommended Lux (light level) for safe forklift work in a warehouse?

.....





Theory Training Task 13

Performance Criterion: 2.3

a) List the **six** levels of the Hierarchy of Hazard Control.

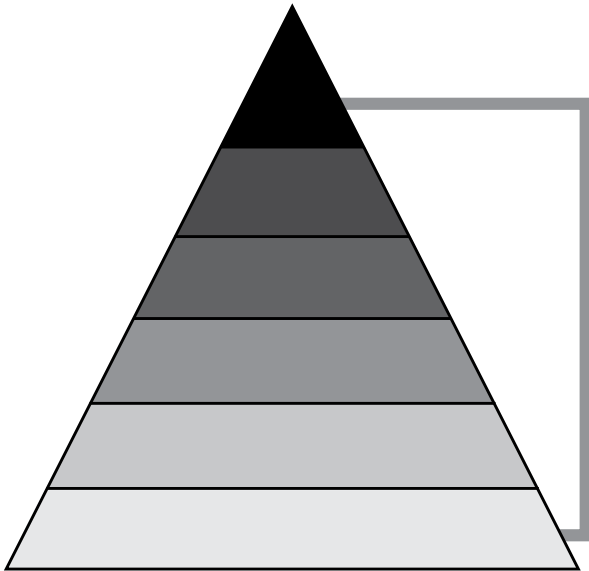

1.
2.
3.
4.
5.
6.

b) What is the first thing you should try if you find a hazard?

.....





Theory Training Task 14

Performance Criterion: 2.3

Label the personal protective equipment in the picture below.

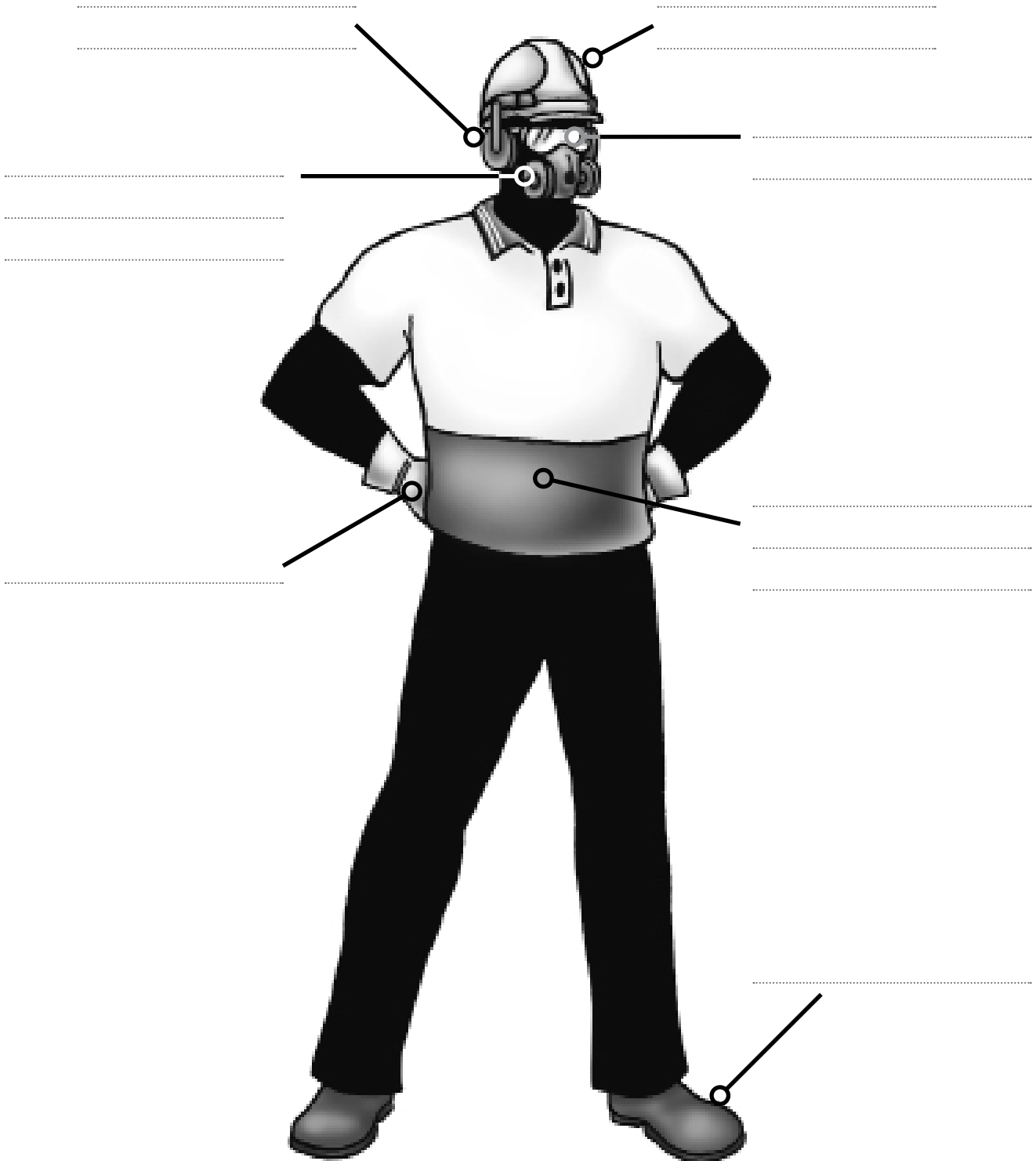

b) Circle the two (2) items that must be worn on every work site when using a forklift.



Theory Training Task 15

Performance Criterion: 2.3

Give an example of why you might have to wear each of the following.

Safety shoes

Hard hat

Ear protection

.....
.....
.....
.....
.....

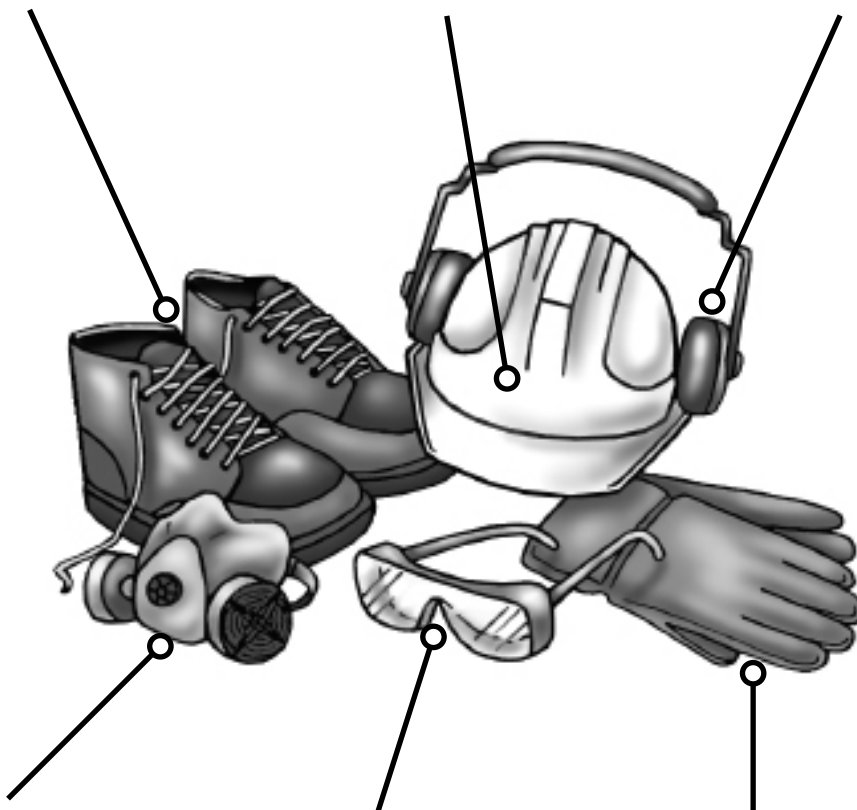

Face mask

Safety glasses

Gloves

.....
.....
.....
.....
.....

Performance Criterion: 1.7

Choose the right forklift truck

There are different types of forklift trucks. Depending on the job and the work area you may need to use a certain type of forklift truck. It's important to use the right type of forklift truck.



Theory Training Task 17

Performance Criterion: 1.7

Label the common parts shown on the diagram below of a counterbalance forklift truck.

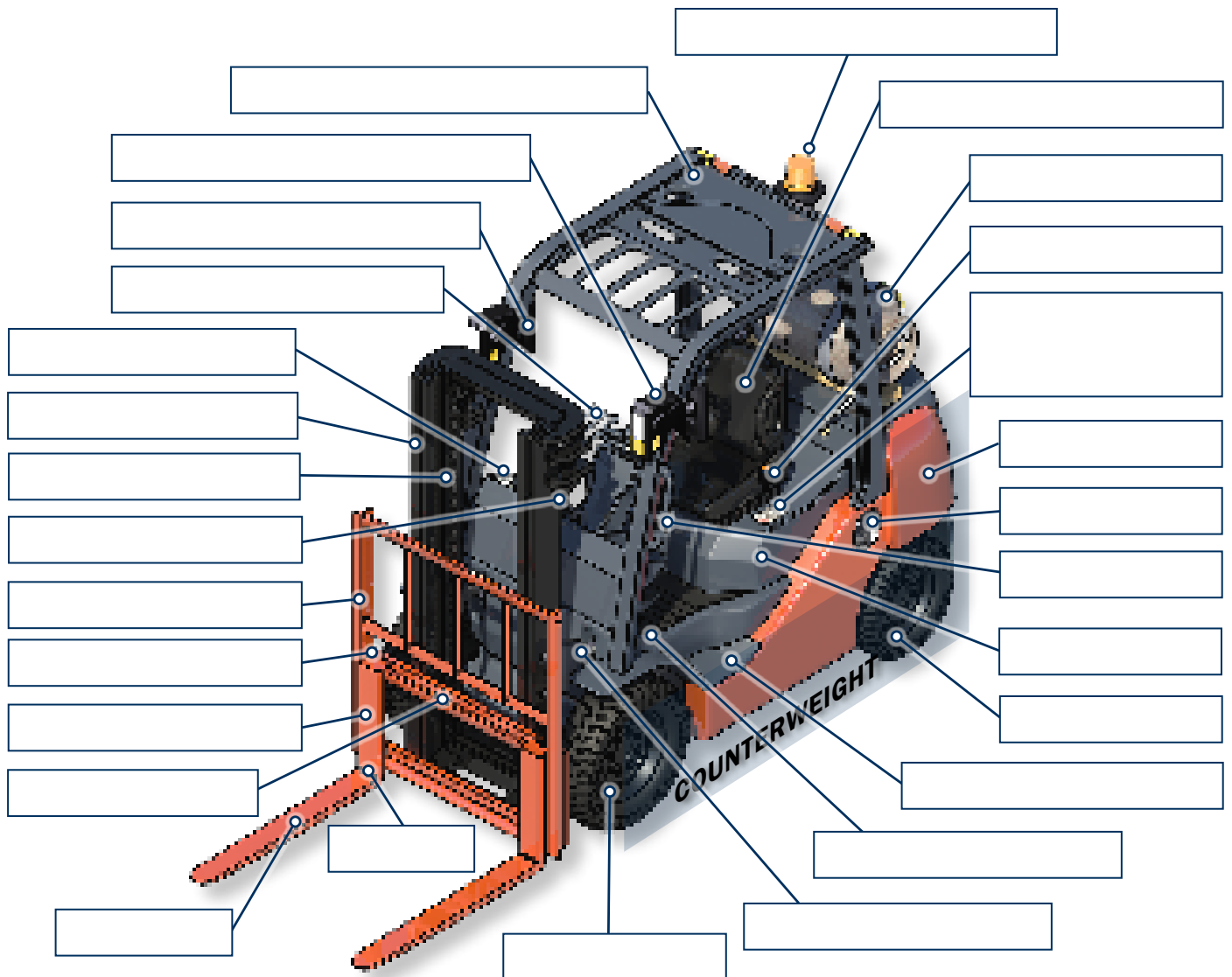

The benefits of using the Logbook

FORKLIFT TRUCK RECORD OF TRAINING LOGBOOK



TLILIC0003
Licence to operate a forklift truck



This book can also be used as an evidence record of recognition of prior learning (RPL) and as evidence of formative assessment tasks

1. Provides a record of practical training.
2. Can be used for on-the-job training.
3. Can be used for verification of competency (VOC).

FORKLIFT TRUCK RECORD OF TRAINING LOGBOOK



TLILIC0003
Licence to operate a forklift truck



This book can also be used as an evidence record of recognition of prior learning (RPL)
and as evidence of formative assessment tasks

Contents

Purpose of this training logbook	6
Requirement of a training logbook.....	7
Sample page	8
Element 1 — Plan work/task	11
Element 2 — Prepare for work/task.....	29
Element 3 — Perform work/task	49
Element 4 — Pack up.....	63

1

Plan Work

PC 1.5

Hazard and risk control measures are identified and reported to relevant person/s in accordance with workplace procedures.

Description of work/training performed

I checked the work site and found out that pedestrians would be walking near where I'd be using the forklift. To prevent an accident, I put up barricades and signs to warn pedestrians that a forklift was working nearby.

I had to move a pallet of chemicals from one area of the warehouse to another. Before moving the chemicals I decided to read and understand the Safety data sheet (SDS). The SDS told me everything I had to know about the chemicals before I moved them.

Before I started work I walked around the route my forklift would take. I found someone had left a pallet of boxes in an aisle. This was the first thing I wrote down on the Job safety analysis (JSA) sheet. I asked another staff member to move the boxes before I used the forklift.

Date/time	No. of hours	Machine details	Supervising person
Date: <u>5 / 4 / 2020</u> Start time: <u>10</u> am pm	20 minutes	Make: <u>Toyota</u> Model: <u>7FG 50</u> Serial No: <u>855745 11</u> Max Capacity: <u>4200</u> kg Load Centre: <u>600</u> mm Lift Height: <u>4000</u> mm	Name: <u>Joseph Burrows</u> Signed: <u>Joseph Burrows</u> Class: <u>Forklift Truck</u> Cert No: <u>323 565 1</u> State of Issue: <u>NSW</u> Issue Date: <u>26 / 01 / 2014</u> Expiry Date: <u>26 / 01 / 2019</u>
Date: <u>7 / 4 / 2020</u> Start time: am <u>2.30</u> pm	10 minutes	Make: <u>Toyota</u> Model: <u>7FG 50</u> Serial No: <u>855745 11</u> Max Capacity: <u>4200</u> kg Load Centre: <u>600</u> mm Lift Height: <u>4000</u> mm	Name: <u>Joseph Burrows</u> Signed: <u>Joseph Burrows</u> Class: <u>Forklift Truck</u> Cert No: <u>323 565 1</u> State of Issue: <u>NSW</u> Issue Date: <u>26 / 01 / 2014</u> Expiry Date: <u>26 / 01 / 2019</u>
Date: <u>8 / 4 / 2020</u> Start time: <u>8</u> am pm	15 minutes	Make: <u>Toyota</u> Model: <u>7FG 50</u> Serial No: <u>855745 11</u> Max Capacity: <u>4200</u> kg Load Centre: <u>600</u> mm Lift Height: <u>4000</u> mm	Name: <u>Joseph Burrows</u> Signed: <u>Joseph Burrows</u> Class: <u>Forklift Truck</u> Cert No: <u>323 565 1</u> State of Issue: <u>NSW</u> Issue Date: <u>26 / 01 / 2014</u> Expiry Date: <u>26 / 01 / 2019</u>

Plan work/task



1

Plan Work

PC 1.1

Task requirements are identified from work orders or equivalent and confirmed with relevant people and site inspection is conducted in accordance with workplace procedures

Description of work/training performed

Date/time	No. of hours	Machine details	Supervising person
Date: Start time: am pm		Make: Model: Serial No: Max Capacity: kg Load Centre: mm Lift Height: mm	Name: Signed: Class: Cert No: State of Issue: Issue Date: Expiry Date:
Date: Start time: am pm		Make: Model: Serial No: Max Capacity: kg Load Centre: mm Lift Height: mm	Name: Signed: Class: Cert No: State of Issue: Issue Date: Expiry Date:
Date: Start time: am pm		Make: Model: Serial No: Max Capacity: kg Load Centre: mm Lift Height: mm	Name: Signed: Class: Cert No: State of Issue: Issue Date: Expiry Date:

FORKLIFT TRUCK FORMATIVE ASSESSMENT

Verification of Competency (VOC)

Learner's copy

TLILIC0003

Licence to operate a forklift truck



Assessment Conditions

As a minimum, assessors must satisfy applicable regulatory requirements, which include requirements in the Standards for Registered Training Organisations current at the time of assessment.

2. Can you operate a forklift if you don't have a High Risk Work (HRW) licence?

3. Your employer has asked you to show evidence of competency before you operate the forklift. What evidence might you need to show?

4. You have passed your high risk work licence test. You must now apply for your high risk work licence. How many days do you have to put the application in?

5. Once you have a high risk work licence you need to keep experienced and up to date (competent). Can you use your high risk work licence if you are no longer experienced and up to date?

6. You need to renew your high risk work licence every 5 years. You must renew your licence within 12 months of the renewal date. What will happen if you don't renew your licence within 12 months of the date it expires?

Note: In Western Australia this period is 24 months.

10. You need to plan for possible hazards before you use the forklift. The hazards could be inside or outside. Name some hazards you might have to plan for. (Identify ten hazards)

11. Before operating the forklift you must inspect the operating surface. Identify three things that you should look for.

12. Are you allowed to put more counterweight on a forklift without checking the manufacturer's instructions?

13. Give three examples of information you will find on the forklift data plate.

14. What does the rated capacity of a forklift mean?

15. What does load centre distance mean?

16. The load centre distance is measured from the vertical face of the forks to the centre of gravity of the load. If the forklift you are using is rated to lift 1000 kg at a 600 mm load centre. Which of the loads below are within the forklifts limits?

Note: The load length has been measured from the vertical face of the forks out to the end of the load.

- A. Load weight 1000kgs, load length 1300mm
- B. Load weight 1023kgs, load length 1190mm
- C. Load weight 1000kgs, load length 1210mm
- D. Load weight 1000kgs, load length 1199mm
- E. Load weight 999kgs, load length 1400mm

17. If the load centre distance increases, for example the load is not pushed up right against the heel of the forks, what can happen?

18. Why is it important to plan your path of travel?

19. When should you set up hazard (risk) controls?

62. You have to move a load of 36 bags of flour on a pallet.

- Each bag of flour weighs 23 kg
- Pallet weighs 30 kg

What is the total weight of the load? Show your working out.

Use this data plate to answer the next five questions (63 – 67)



FORK TRUCK LOAD AND WARNING NOTICE

Operators must be trained and authorised. Do not operate the lift truck if it is in need of repair. This capacity plate is not transferable and is invalidated by any change to specifications.

MODEL:	A12345A	S/NO:	123456	MAST:	2W370
MAST/CARRIAGE TILT DEGREES:			TYRE PRESSURES KPA:		
FORWARD/DOWN:	6	FRONT:	686		
BACK/UP:	12	REAR:	686		
DRIVE WHEELS:	SINGLE	TYRE TYPE:	PNEUMATIC		
TRACTION BATTERY WEIGHT (KG) MIN:	N.A.	MAX:	N.A.	VOLT:	N.A.
TARE WEIGHT WITHOUT TRACTION BATTERY (KG):	2745	HIRE 921			

RATED CAPACITIES - SIDESHIFT & LOAD IN CENTRE POSITION

	LOAD CENTRE (MM)	LIFT/LOAD HEIGHT (MM)	MAST VERTICAL CAPACITY (KG)	MAST FORWARD CAPACITY (KG)
SIDESHIFT	600	3700	1575	900

PLATE I.D.: **12345**

DEALER: **EASY GUIDES PTY LTD**

FORKLIFT TRUCK FORMATIVE ASSESSMENT

Verification of Competency (VOC)

Learner's copy

TLILIC0003

Licence to operate a forklift truck



Assessment Conditions

As a minimum, assessors must satisfy applicable regulatory requirements, which include requirements in the Standards for Registered Training Organisations current at the time of assessment.

2. Can you operate a forklift if you don't have a High Risk Work (HRW) licence?

3. Your employer has asked you to show evidence of competency before you operate the forklift. What evidence might you need to show?

4. You have passed your high risk work licence test. You must now apply for your high risk work licence. How many days do you have to put the application in?

5. Once you have a high risk work licence you need to keep experienced and up to date (competent). Can you use your high risk work licence if you are no longer experienced and up to date?

6. You need to renew your high risk work licence every 5 years. You must renew your licence within 12 months of the renewal date. What will happen if you don't renew your licence within 12 months of the date it expires?

Note: In Western Australia this period is 24 months.

10. You need to plan for possible hazards before you use the forklift. The hazards could be inside or outside. Name some hazards you might have to plan for. (Identify ten hazards)

11. Before operating the forklift you must inspect the operating surface. Identify three things that you should look for.

12. Are you allowed to put more counterweight on a forklift without checking the manufacturer's instructions?

13. Give three examples of information you will find on the forklift data plate.

14. What does the rated capacity of a forklift mean?

15. What does load centre distance mean?

16. The load centre distance is measured from the vertical face of the forks to the centre of gravity of the load. If the forklift you are using is rated to lift 1000 kg at a 600 mm load centre. Which of the loads below are within the forklifts limits?

Note: The load length has been measured from the vertical face of the forks out to the end of the load.

- A. Load weight 1000kgs, load length 1300mm
- B. Load weight 1023kgs, load length 1190mm
- C. Load weight 1000kgs, load length 1210mm
- D. Load weight 1000kgs, load length 1199mm
- E. Load weight 999kgs, load length 1400mm

17. If the load centre distance increases, for example the load is not pushed up right against the heel of the forks, what can happen?

18. Why is it important to plan your path of travel?

19. When should you set up hazard (risk) controls?

62. You have to move a load of 36 bags of flour on a pallet.

- Each bag of flour weighs 23 kg
- Pallet weighs 30 kg

What is the total weight of the load? Show your working out.

Use this data plate to answer the next five questions (63 – 67)



FORK TRUCK LOAD AND WARNING NOTICE

Operators must be trained and authorised. Do not operate the lift truck if it is in need of repair. This capacity plate is not transferable and is invalidated by any change to specifications.

MODEL:	A12345A	S/NO:	123456	MAST:	2W370
MAST/CARRIAGE TILT DEGREES:		TYRE PRESSURES KPA:			
FORWARD/DOWN:	6	FRONT:	686		
BACK/UP:	12	REAR:	686		
DRIVE WHEELS:	SINGLE	TYRE TYPE:	PNEUMATIC		
TRACTION BATTERY WEIGHT (KG) MIN:	N.A.	MAX:	N.A.	VOLT:	N.A.
TARE WEIGHT WITHOUT TRACTION BATTERY (KG):	2745	HIRE 921			

RATED CAPACITIES - SIDESHIFT & LOAD IN CENTRE POSITION

	LOAD CENTRE (MM)	LIFT/LOAD HEIGHT (MM)	MAST VERTICAL CAPACITY (KG)	MAST FORWARD CAPACITY (KG)
SIDESHIFT	600	3700	1575	900

PLATE I.D.:	12345	DEALER:	EASY GUIDES PTY LTD
-------------	--------------	---------	----------------------------

FORKLIFT TRUCK

Mapping Document

TLILIC0003

Licence to operate a forklift truck



Industry Training Resources

The information and questions contained in the Safety and licence guide/PowerPoint presentation, Learner workbook/Assessment and Logbook have been mapped to the elements, performance criteria, and knowledge and performance evidence for the unit of competency TLILIC0003 Licence to operate a forklift truck.

Elements and performance criteria

Element 1	Performance Criteria	Safety and licence guide and PowerPoint	Learner workbook and Trainer’s marking guide	Formative Assessment
Plan work/task	1.1 Task requirements are identified from work orders or equivalent and confirmed with relevant people and site inspection is conducted in accordance with workplace procedures	<ul style="list-style-type: none"> • Task requirements • Site inspection • Hazards - Indoors • Hazards - outdoors <p>Question 11, 12, 13</p>	Theory Training Task 24	Question 1 Questions 9 - 36
	1.2 Work area operating surface is assessed to determine suitability for operational use of forklift truck in accordance with workplace procedures	<ul style="list-style-type: none"> • Inspect the operating surface 	Theory Training Task 8, 20	Question 1, 10, 25
	1.3 Suitability of forklift truck and attachment working load limit (WLL) is determined for the load/s and work/task requirements in accordance with manufacturer requirements and workplace procedures	<ul style="list-style-type: none"> • Counterbalance forklift • Suitability of forklift and attachment • Rated capacity • Checking the rated capacity • Load centre distance • Calculating the load centre distance • Things that affect load centre distance <p>Question 3, 14, 15, 16, 17, 18, 19</p>	Theory Training Task 18, 20, 21, 36, 57, 58,60, 61	Question 9, 12, 13, 14, 16, 17

Element 1	Performance Criteria	Safety and licence guide PowerPoint	Learner workbook and Marking guide	Formative Assessment
Plan work/task	1.4 Working area is inspected and appropriate paths for operating the forklift truck and moving and placing load/s in work area are assessed and managed in accordance with workplace procedures	<ul style="list-style-type: none"> • Path of travel 	Theory Training Task 4, 22, 24 Practical Training Task 1	Question 10, 27, 28, 73, 85 Practical Assessment Part 1: The work area.
	1.5 Hazard and risk control measures are identified and reported to relevant person/s in accordance with workplace procedures	<ul style="list-style-type: none"> • Hazard control • The operator • Refuelling and recharging • Overhead powerlines • Overhead powerlines on poles • Overhead powerlines on poles • Working closer to powerlines • Tiger tails • Lighting • Confined spaces • Personal protective equipment (PPE) • PPE examples Question 20, 21, 22, 23, 24, 25, 26, 27, 28, 29, 30, 31	Theory Training Task 1, 2, 4, 5, 6, 7, 8, 9, 23, 62 Practical Training Task 1	Question 9, 10, 19, 28, 32, 33, 56 Practical Assessment Part 1 Practical Assessment Part 2 – Forklift suitability Practical Assessment Part 3 – Applicant checks risk control measures for hazards.